

SERIES 100D/150D(Duplex)

Installation, Operation and Maintenance Manual Addendum

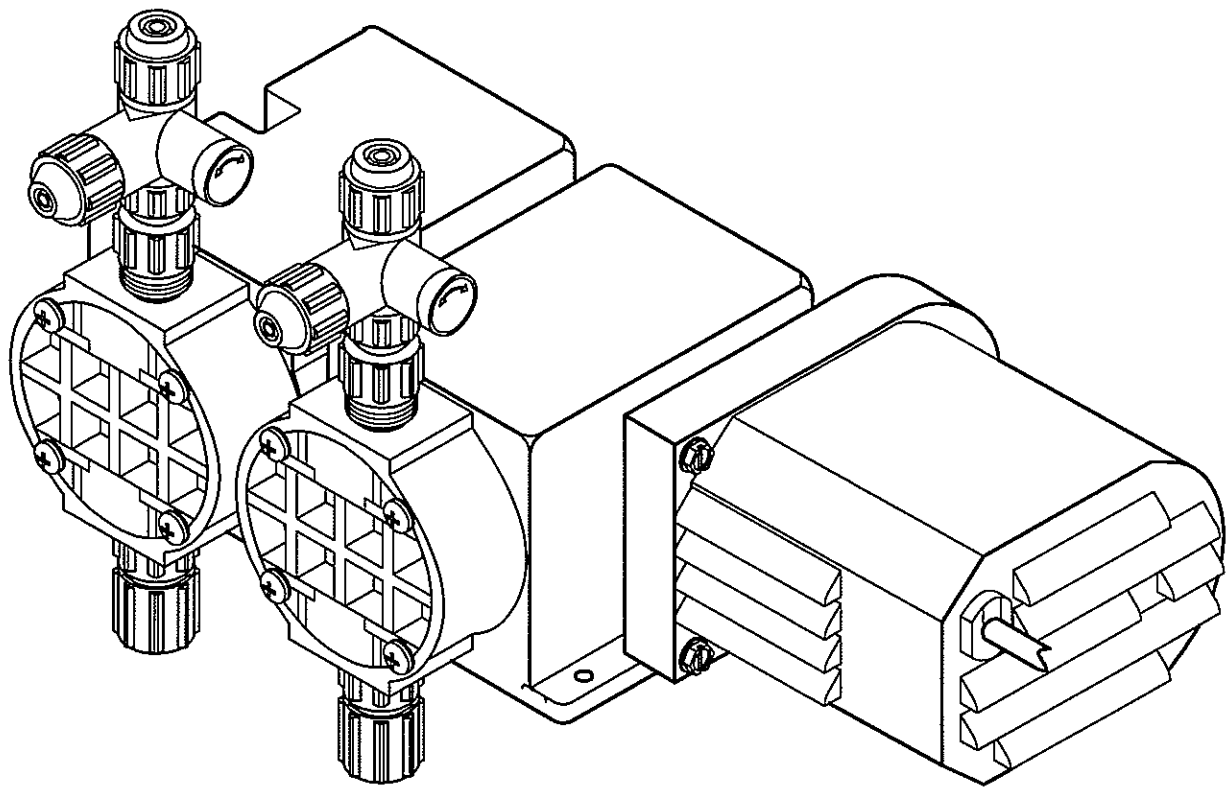

CHEMICAL SOLUTION FEED PUMPS

READ ALL WARNINGS CAREFULLY BEFORE INSTALLING PUMP

INTRODUCTION:

The Series 100D/150D are duplex diaphragm-type feed pumps. The operating principle of each individual pumping assembly is identical to that of the Series 100/150 chemical pump. Standard materials of construction and optional materials for the pump assemblies(wet end parts) are completely interchangeable with all Series 100/150 and 200 models.

CAUTION : BE SURE TO NOTE CAUTION SECTION OF THE SERIES 100/150 INSTRUCTION MANUAL(pt.#32040).

The carton should contain(See Figure -A-):

- ONE DUPLEX FEEDER,
- TWO LENGTHS, 4-ft.(1.2m) CLEAR FLEXIBLE SUCTION TUBING,
- TWO LENGTHS, 8-ft.(2.4m) STIFF WHITE DISCHARGE TUBING,
- TWO BACK CHECK VALVE ASSEMBLIES,
- TWO STRAINER ASSEMBLIES,
- A MANUAL ADDENDUM,
- TWO BLEED VALVE ASSEMBLIES,
- TWO LENGTHS, 4-ft.(1.2m) STIFF WHITE RETURN TUBING

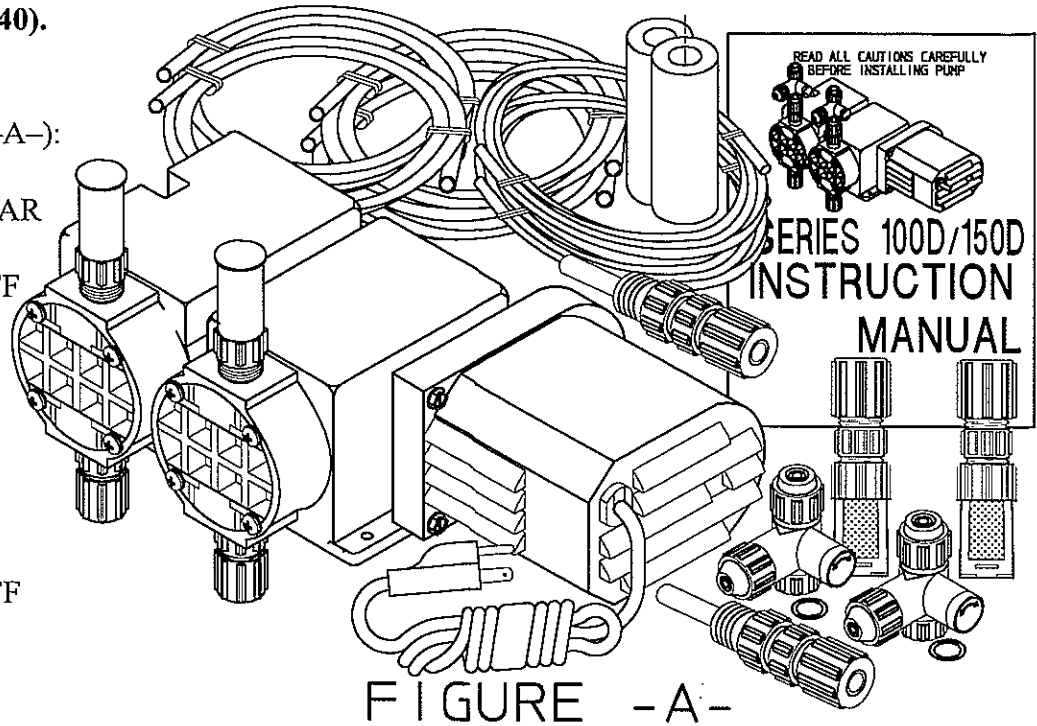

FIGURE -A-

UNPACKING, ASSEMBLING AND MOUNTING;

These pumps can be mounted on a wall shelf bracket(Figure -B-), tank stand(Figure -C-) or directly on the tank cover(Figure -D-). As with the Series 100/150 and 200 feeders, flooded suction mounting(installing pump at the base of a tank on a platform) is the most trouble-free type of installation. Since the suction tubing is always filled with solution, priming is accomplished much more quickly and the chance of losing prime is greatly reduced. Tank stands and platforms are available for all Series pumps and tanks.

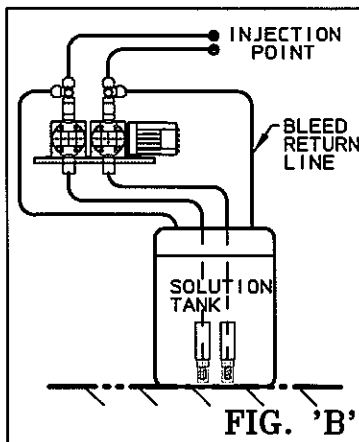

FIG. 'B'

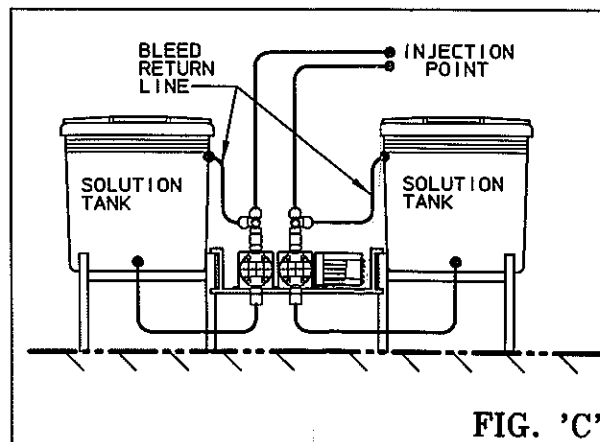

FIG. 'C'

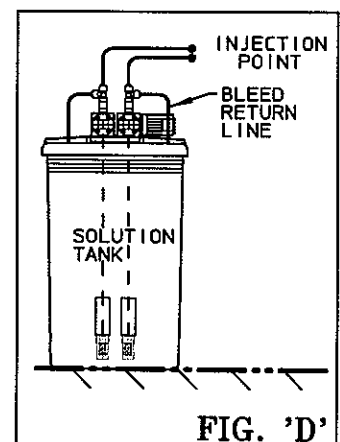
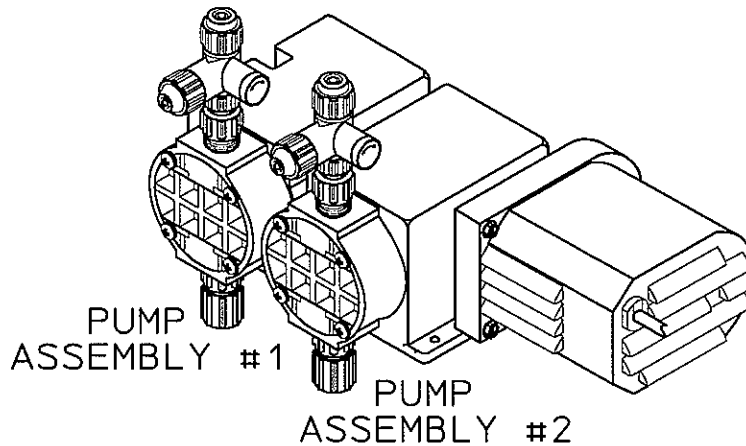

FIG. 'D'

INSTALLATION, OPERATION AND MAINTENANCE

Installation, operation and maintenance of the Series 100D/150D is very similar that of the Series 100/150 models(consult the Series 100/150 instruction manual(pt.#32040) for further information). The obvious difference is the 100D/150D utilize two pumping assemblies with a single drive unit. This allows metering chemical from a single tank to two distinct injection points or two different chemicals from two tanks to either the same point of injection or to two points of injection. Also each pumping assembly is independently adjustable, allowing a wide range of flow adjustments. NOTE: THE DIAL LABELS FOR THE SERIES 100D/150D ARE CALIBRATED IN PERCENTAGE(0-100%) NOT GALLONS PER DAY(GPD). ACTUAL OUTPUT FOR EACH PUMPING ASSEMBLY CAN BE DETERMINED BY MULTIPLYING THE PERCENT VALUE INDICATED BY THE POSITION OF THE DIAL BY THE MAXIMUM OUTPUT SHOWN ON THE DATA LABEL. When pumping different solutions, it is possible that different materials of construction for each pumping assembly will be required. In addition to color coding materials and plainly marking different materials of construction for accessories, the outside of the carton will be clearly marked indicating the materials used for each pumping assembly. The assembly nearest the motor is pump assembly #2. The outside assembly is pump assembly #1(Figure –E–). The markings on the carton make this distinction.

NOTE: START UP, MAINTENANCE, SERVICING AND REPAIR INFORMATION CAN BE FOUND IN THE SERIES 100/150 MANUAL(pt.#32040).



⚠ CAUTION : BE SURE THE CORRECT MATERIALS OF CONSTRUCTION ARE APPLIED WHEN PUMPING TWO DIFFERENT SOLUTIONS. WHEN IN DOUBT, CONTACT YOUR CHEMICAL SUPPLIER TO DETERMINE COMPATIBILITY.

NOTE: SINCE THE SERIES 100D/150D CAN BE PROVIDED WITH EACH PUMP ASSEMBLY CAPABLE OF DIFFERENT MAXIMUM OUTPUTS, A SEPARATE DATA LABEL IS APPLIED TO EACH PUMP HOUSING. THESE DATA LABELS WILL INDICATE THE MAXIMUM CAPACITY OF EACH PUMPING ASSEMBLY.

TROUBLE SHOOTING

Since the Series 100D/150D pumping assemblies operate independently of each other, troubleshooting procedures are the same as with the Series 100/150. Consult the troubleshooting section of the Series 100/150 manual(pt.#32040).

D100/D150 FINAL ASSEMBLY

ITEM	PART #	DESCRIPTION	QTY
*20	22255	CAM/BEARING ASS'Y	2
	22256	CAM/BEARING ASS'Y	
	22257	CAM/BEARING ASS'Y	
21	28903	HEAD ASS'Y PROD.SAN/HYP/C	2
22	24820	CORD, 6' 115VAC	1
	24821	CORD, 6' 230VAC	
23	J40710	TERMINAL, END CON	2
24	L9900700-000	CONNECTOR, STRAIN RELIEF	1
25	J37005	SCREW, #10-24 x 2'lg. P.H.P. SST	8
26	37031	SCREW, #8-AB x .38'lg. H.W.HD	1
27	37032	SCREW, #8-B x .44'lg. H.W.HD	2
28	J37033	SCREW, #8-B x .50'lg. H.W.HD	3
29	37047	SCREW, SET #10-32 x .25'lg.	4
30	37049	SCREW, SET #10-32 x .75'lg.	3
31	37061	SCREW, SET #10-32 x .19'lg.	2
32	37060	SCREW, SET #8-32 x .13'lg. (NOT SHOWN)	2
1-B	42041	WASHER, .26" I.D. STL	2
34	J42020	WASHER, #10 STL	11
35	42045	WASHER, #8 EXT. RH LOCK STL	1
36	L9800600-STL NUT, #10-32 HEX		3

* - SEE NOTE #2.

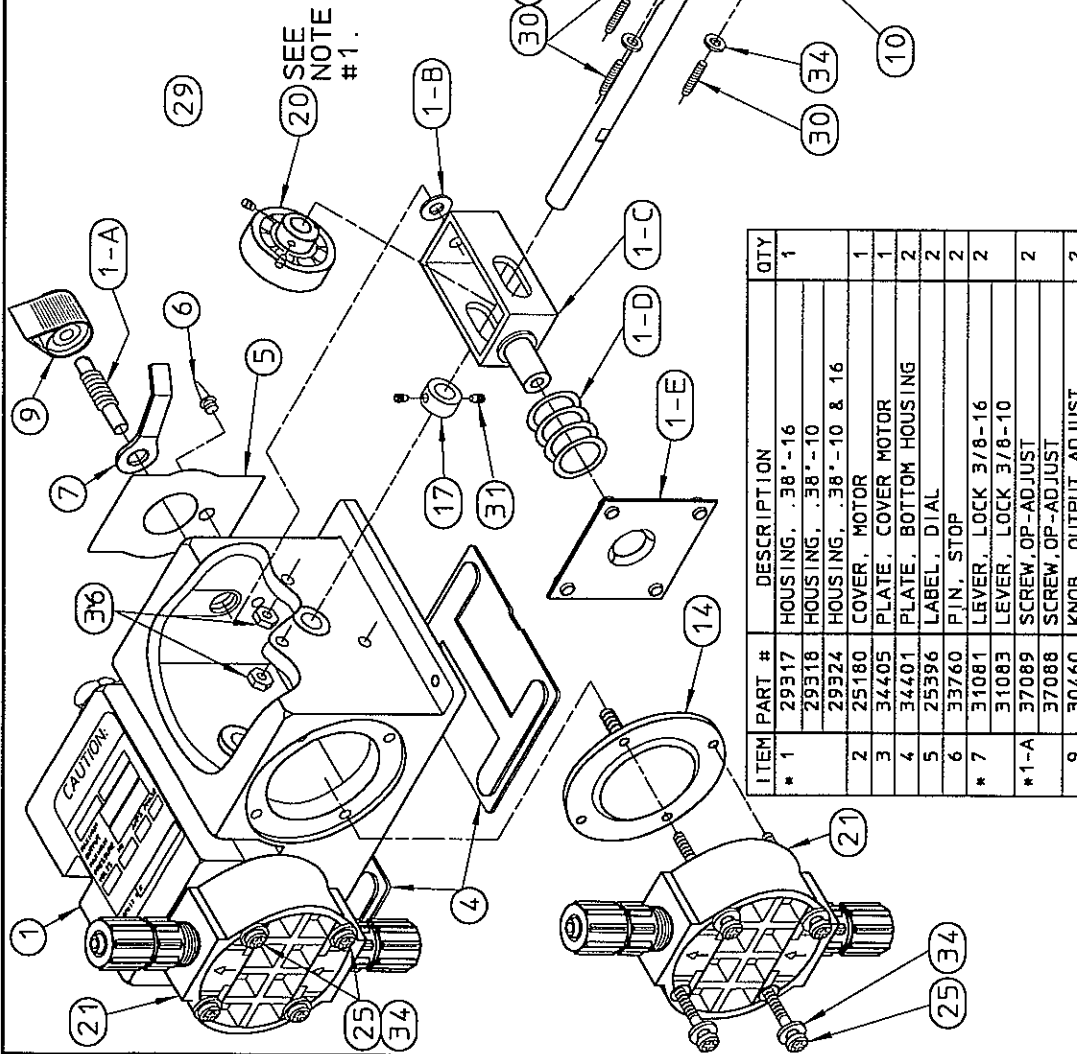

ITEM	PART #	DESCRIPTION	QTY
* 1	29317	HOUSING, .38"-16	1
	29318	HOUSING, .38"-10	
	29324	HOUSING, .38"-10 & 16	
2	25180	COVER, MOTOR	1
3	34405	PLATE, COVER MOTOR	1
4	34401	PLATE, BOTTOM HOUSING	2
5	25396	LABEL, DIAL	2
6	33760	PIN, STOP	2
* 7	31081	LEVER, LOCK 3/8-16	2
	31083	LEVER, LOCK 3/8-10	
* 1-A	37089	SCREW, OP-ADJUST	2
	37088	SCREW, OP-ADJUST	
9	30460	KNOB, OUTPUT ADJUST	2

NOTES:

- NOTE THAT THE 2 CAMS ARE 180° OUT OF PHASE ON MOTOR SHAFT.
- * VARY w/ PUMP MODEL NUMBER CONTACT DEALER TO DETERMINE CORRECT REPLACEMENT.

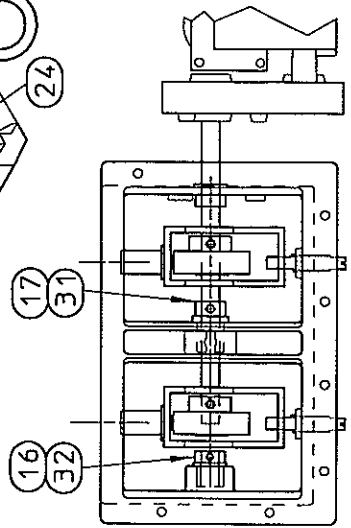

ITEM	PART #	DESCRIPTION	QTY
10	J62015/J62011/J62007	MOTOR, 7-rpm/115v/230v60hz/230v50hz	1
	J62016/J62012/J62008	MOTOR, 13-rpm/115v/230v60hz/230v50hz	
	J62017/J62013/J62009	MOTOR, 25-rpm/115v/230v60hz/230v50hz	
	J62018/J62014/J62010	MOTOR, 51-rpm/115v/230v60hz/230v50hz	
14	25704	DIAPHRAGM(HYPALON), AS'Y	2
1-E	J34379	BACKING PLATE ASS'Y	2
16	23700	COLLAR, MOTOR SHAFT	1
17	23701	COLLAR, MOTOR SHAFT	1
1-D	38980	SPRING, DIAPHRAGM RETURN	2
1-C	21829	BRACKET ASS'Y, DRIVE	2

* - SEE NOTE #2.