

9. ABC BOILER CONTROLLER SERIES

A. KEY FEATURES:

- Front panel calibration.
- Front panel dial set point.
- Conductivity ranges 0-500, 1000, 2000, 5000, 10000, and 20000 $\mu\text{S}/\text{cm}$.
- Blow down indicator LED.
- Relay test switch.
- Power indicator LED.
- Weather-tight enclosure designed to NEMA 4X.
- Wall mountable.

B. ABC MODEL STANDARD FEATURES:

- Analog meter conductivity controller, selectable scale 0-500, 1000, 2000, 5000 and 20,000 $\mu\text{S}/\text{cm}$

C. OPTIONS:

- P5 230 VAC @ 50 Hz.
- P6 230 VAC @ 60 Hz.
- R BN2-TC (temp. comp. probe)
- V Agency Approval US/Canada
- V1 Agency Approval "CE"
- W Private Label

PULSAFEEDER®

**ANALOG BOILER
CONTROLLER**

MODEL ABC 102

**INSTALLATION
OPERATION
MAINTENANCE
INSTRUCTION**

CALL 1-800-577-8111 FOR SALES AND SUPPORT

PULSAFEEDER®

A Unit of IDEX Corporation

27101 Airport Road
Punta Gorda, FL 33982

Toll free: 1-800-333-6677
Phone: 1-941-575-3800
Toll free Fax: 1-800-456-4085
Fax: 1-941-575-4085

ABC™ FACTORY SERVICE POLICY

Your ABC™ controller is a state of the art electronic based unit. If you are experiencing a problem with your ABC™ controller, first consult the troubleshooting guide in your operation and maintenance manual. If the problem is not covered or cannot be solved, please contact our Technical Services Department for further assistance. Trained technicians are available to diagnose your problem and arrange a solution. Solutions may include purchase of replacement parts or returning unit to the factory for inspection and repair. All returns require a Return Authorization number to be issued by Pulsafeeder. Parts purchased to correct a warranty issue may be credited after an examination of original parts by Pulsafeeder. Warranty parts returned as defective which test good will be sent back freight collect. No credit will be issued on any replacement electronic parts.

Any modifications or out-of-warranty repairs will be subject to bench fees and costs associated with replacement parts.

ABC™ WARRANTY

Pulsafeeder, Inc. warrants ABC™ control systems of its manufacture to be free of defects in material or workmanship. Liability under this policy extends for 24 months from date of shipment. The manufacturer's liability is limited to repair or replacement of any failed equipment or part which is proven defective in material or workmanship upon manufacturer's examination. This warranty does not include removal or installation costs and in no event shall the manufacturer's liability exceed the selling price of such equipment or part. The manufacturer disclaims all liability for damage to its products through improper installation, maintenance, use, or attempts to operate such products beyond their functional capacity, intentionally or otherwise, or any unauthorized repair. The manufacturer is not responsible for consequential or other damages, injuries, or expense incurred through the use of its products.

The above warranty is in lieu of any other warranty, whether expressed or implied. The manufacturer makes no warranty of fitness or merchantability. No agent of ours is authorized to provide any warranty other than the above.

ELECTRODE ASSEMBLY

ITEM	DESCRIPTION
7	GROSS, 1' 2000LBS
6	8N-1/4H-1RS BOILER PROBE
5	UNION, BOILER, 1/2" L500
4	NIPPLE, 1/2" X CLOSE, GALVANIZED
3	GASKET, ACCESS TEE, 1/2", OLKRG
2	COVER, ACCESS TEE, 1/2" OL10
1	ACCESS TEE 1/2" OT 1

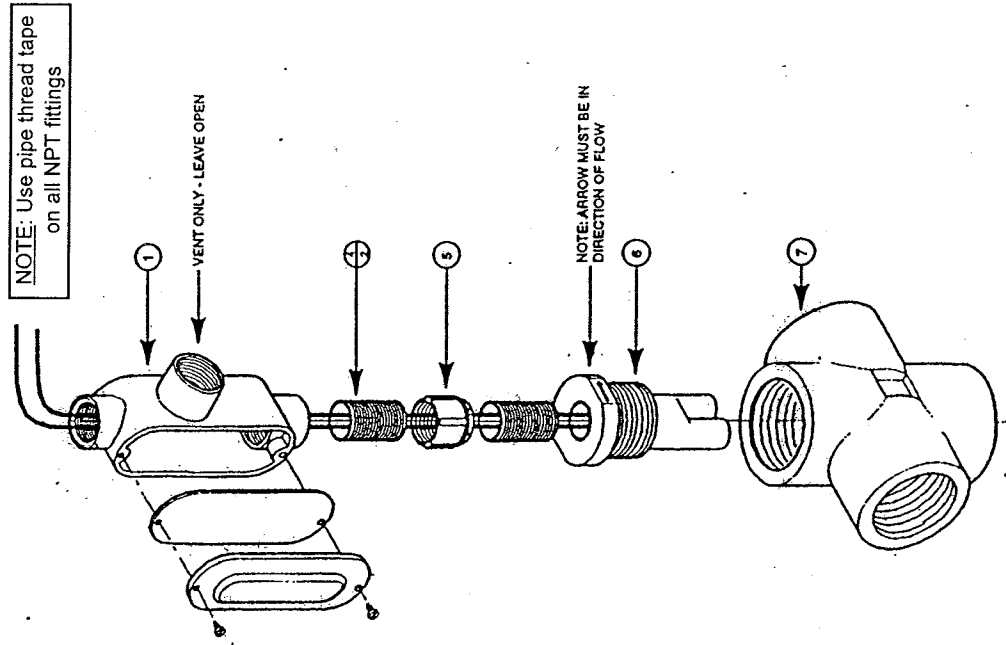

8. ENCLOSURE DIAGRAM AND PARTS LIST

ENCLOSURE ASSEMBLY

ITEM	DESCRIPTION
17	SCREW, 1/4-20 X, 500 LONG
16	INSERT BRASS, 1/4-20
15	RIBBON CABLE
14	SCREW, 6-16 X, 1.00
13	LONG, SELF TAPPING STANDOFF, 1/4 HEX, 1.75 LONG
12	KNOB, 1/4 INSERT W/SET SCREW
11	SCREW, #6-32
10	O-RING, 441 OD, .301 ID, .070 THK
9	ROLL PIN
8	SCREW
7	BRACKET, WALL FLOW MTG. ENCLOSURE
6	MOUNTING PANEL
5	MAIN ASSY ABC PCB
4	PANEL, MAIN PCB MTG. GASKET, ENCLOSURE COVER, CONTROLLER
3	
2	
1	

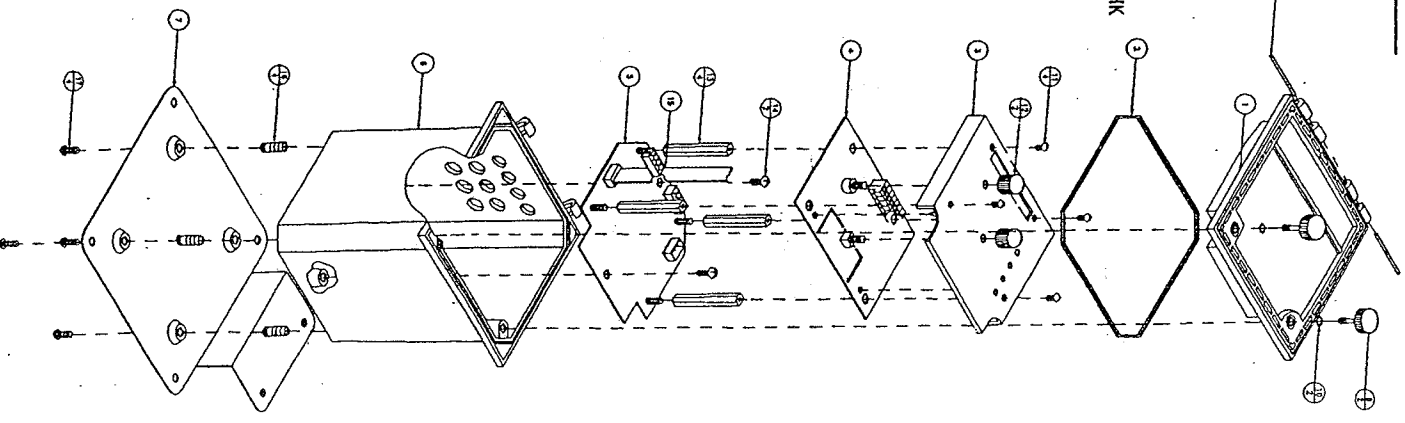

PULSAFEEDER

ANALOG BOILER CONTROLLER

MODEL ABC 102

CONTENTS

- 1. INTRODUCTION 3
- 2. INSTALLATION 4
- 3. OPERATION 7
- 4. ELECTRODE REMOVAL, CLEANING AND REINSTALLATION 11
- 5. MAINTENANCE 12
- 6. TROUBLE SHOOTING GUIDE 13
- 7. ENCLOSURE DIAGRAM AND PARTS LIST 14
- 8. ABC SERIES LINE UP AND OPTIONS 16

1. INTRODUCTION

The Pulsafeeder ABC Controllers are used to control total dissolved solids (TDS) in steam boiler systems, in terms of electrical conductivity measured in microsiemens per centimeter (µS/cm). They are designed using the latest technology.

The units are very accurate and easy to use. This simplified design provides automated control at an economic cost.

The ABC Series comes standard with connections for A.C. power and blow down activation.

2. Installation

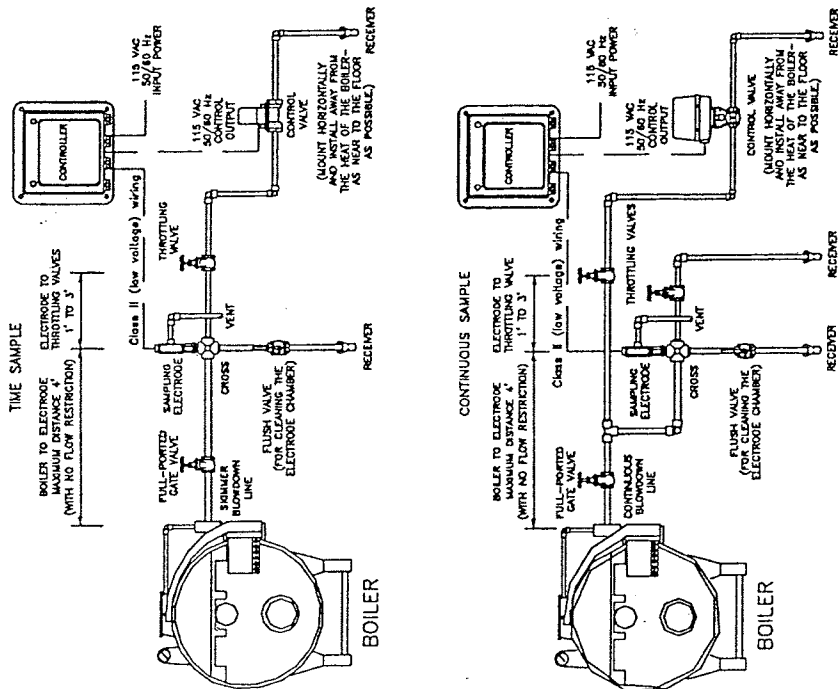

Fig. 1, Typical Installation Diagram

A. LOCATION:

The ABC Series Controllers are designed for ease of installation. Select a mounting location convenient to electrical and plumbing connections and easily accessible by the operator for cleaning and maintenance. The enclosure is corrosion resistant and will stand up to most industrial environments. Be sure unit is free from vapors and liquid spills (refer to Fig. 1, Typical Installation Diagram). Installation should comply with all national, state, and local codes.

B. MOUNTING:

Mount Controller vertically on a wall or a permanent vertical support with adequate lighting and at a comfortable level (refer to Fig. 2, Controller Dimensions).

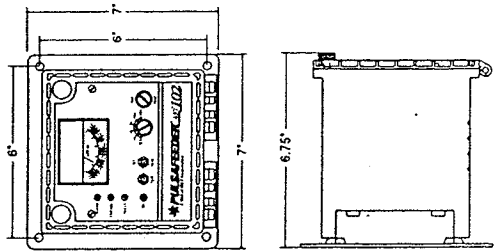

Fig. 2, Controller Dimensions

7. TROUBLE-SHOOTING GUIDE

SYMPTOM

POSSIBLE CAUSE

SOLUTION

Power light is not on	Blown fuse	Replace fuse with Wickman 19372-041K (1 amp) or equivalent.
Relay fuse blows repeatedly	No power supplied to unit External component defective	Check line circuit breaker. Fuse is "T" type. Disconnect external loads. If this prevents the fuse from blowing, plug each external load in, one-by-one, until the fuse blows. Repair or replace defective component. Max. 5 amp resistive (Wickman 19372-063K, 5 amp or equivalent). Use a motor contractor to control the valve. Fuse is "T" type.
Control light stays on	Conductivity of water sampled is beyond range of controller Probe leads shorted Bleed valve plugged - no bleed off Insufficient or no flow past electrode. Blow down line throttled too much	Check the conductivity of the water with a conductivity tester and compare readings. Unplug probe leads, light should go off. Check lead for shorts. Clean or replace valve. Remove obstruction in sample line. Increase blow down rate.
Control light does not come on	Leaking system	Check blow down valves.
Control light goes on and off every few minutes	Electrode is airbound	Bleed air from electrode by allowing water to completely fill and flow through it to drain. Adjust throttling valve so that only water flows across the probe. Check surface skimmer 4 to 4 inches below surface
Wide variation in solution	Poor circulation through conductivity electrode	Clean electrode.
Conductivity of solution is slowly rising	Bleed rate exceeds make-up water rate Bleed rate too low	Decrease bleed rate. Increase bleed rate.
Bleed-off solenoid or other electrical device being operated by the controller does not operate.	Electrode fouled or dirty Bleed rate too low Inoperative solenoid valve Wiring between solenoid	Clean or replace electrode. Increase bleed rate. Replace valve coil or valve as required.
Improper pressure differential across solenoid valve	Improper voltage	Rewire this connection. To check solenoid valve and control defective valve, disconnect it from the controller and energize it from a separate power source. Check for correct valve coil voltage; should be 115 VAC. (Optional 220 VAC.)
	Improper pressure differential across solenoid valve	Check piping and pressure at your location to make sure at least the minimum pressure exists across your solenoid.

5. MAINTENANCE

A. SET UP A MAINTENANCE PROGRAM FOR YOUR CONTROLLER.

Normally, the electronic circuitry in the controller will not require maintenance. However, ambient temperature, humidity changes, and aging can affect the calibration of the controller. Electrodes will become dirty over a period of time and will require cleaning. The frequency of cleaning depends on the installation and the water that comes in contact with the electrode.

During the first few months of operation, check the electrode each week. This allows you to determine how often to clean the electrode. After the first few months of operation, you will be able to establish a proper maintenance schedule for your system. Check the electrode and controller calibration at least once every two months. The more frequent the maintenance, the more assurance you have of reliable controller performance.

By observing readings before and after electrode cleaning, you can determine how often to clean the electrode. If no change or only a small change in readings occurs, clean the electrode less often. If a large change in readings occurs, clean the electrode more often. See Cleaning the Electrode on page 11 of this manual.

B. ACCURACY AND READINGS

The conductivity of any solution changes with the temperature of that solution. The ABC controllers are compensated to 20°C (63°F). In most water solutions, temperature changes affect the conductivity by about 1% per degree Fahrenheit from ambient.

Temperature compensation is effective across a range of 20° to 200°C (68° to 392°F). The controller should provide readings that are consistent with any accurate temperature compensated test instrument for this temperature range.

NOTE: Only if the probe used is a temperature compensated probe will the ABC controller yield temperature compensated readings.

6. ENVIRONMENT

The operating environment of your controller is -25°C to 55°C, 5% to 100% relative humidity, and 0.028 max moisture Kg/Kg dry, (ISA82 Class C2).

C. ACCESSORIES:

(Available through your Pulsafeder distributor or sales representative, but not included as standard)

Boiler Conductivity Timed Sample

1. Blow down valve, solenoid and strainer or motor operated ball valve.
2. Needle Valve or orifice union and plates for throttling blow down.
3. A full-port gate valve for isolation of blow down assembly.
4. A flush valve for sensor.

Boiler Conductivity Continuous Sample

1. Blow down valve, solenoid and strainer or motor operated ball valve.
2. Two needle valves or two orifice unions and plates for throttling blow down.
3. A full-port gate valve for isolation of blow down assembly.
4. A flush valve for sensor.

D. PLUMBING:

A flow rate of at least 1 gpm (gallons per minute) at the electrode is required for proper operation.

Install hand valves on both sides of electrode to relieve pressure at the electrode for easy removal and periodic maintenance.

CAUTION: Do not inject chemical up stream of probe or sensors. This will cause inaccurate readings at the controller.

Direction of flow should be inline with the arrow on the probe assembly. Take time to review Fig. 1, Typical Installation Diagram, and note locations of hand valves, etc. for proper operation and maintenance of all components in the system loop. The throttling valve must be adjusted so that water flows across the probe, not steam.

E. ELECTRICAL:

The ABC controller has been configured to physically separate the low and high voltage connections. Use only 16 or 18 AWG wire for conduit power and load connections. Install according to IEC 1010 Clause 6.

Always use caution when making any electrical connection. Follow all applicable electrical codes. The supply power should be disconnected at the main before making any (low or high voltage) connections.

1) High Voltage Connection

Please refer to Fig. 3A and 3B, High Voltage Connections. Units must be wired by the customer in accordance with all applicable electrical codes (i.e., NEC). When maximally loaded, the unit will draw 10.5 Amps. Each relay is capable of supplying 5 Amps. Size wiring accordingly.

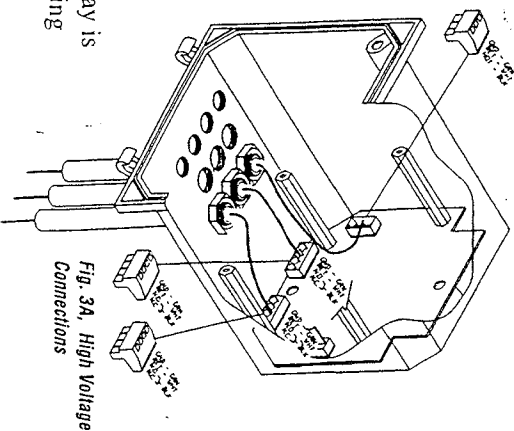

The ABC 102 has two fuses for protection, a 1 amp fuse for the controller power supply, and a 5 amp fuse for the relay output. Part numbers can be found in the Trouble Shooting section.

Connections: Connect the supply and loads per the following table:

Circuit Designator	Connection Type
HOT or NO/NC	Line
RET	Return
\overline{A}	Ground

Connect Supply Power to J11.
Connect loads controlled by conductivity/timer to J7 and J10 (e.g., blow-down solenoid valve). The load connection can be configured to supply power in the "Normally Open" or "Normally Closed" state by attaching the Line wire to the terminal labeled NO and NC respectively.

Figure 3B at right illustrates how an actuated (motorized) ball valve, which is used for "blow down", is connected to the ABC Controller. It employs a normally open (NO), a normally closed (NC), and common (or neutral) connections. In this example, the first device is connected at J7. Location is behind control panel (see Fig. 3A).

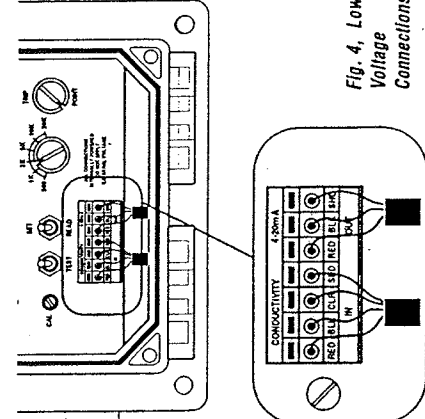
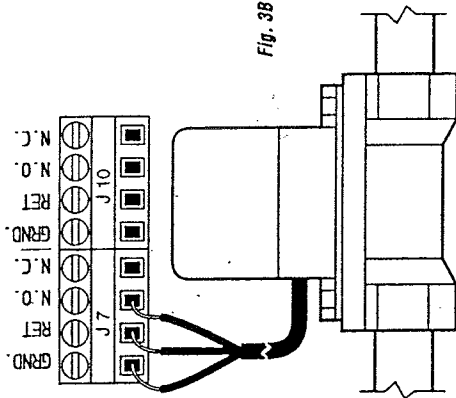

2) Low Voltage Connection
Please refer to Fig. 4, Low Voltage Connections. Generally, low voltage wires are color coded to the designators printed on the front overlay. Make these connections after making the high voltage connections and re-assembling the panel to the front of the unit.
The insulation on the low voltage wires is stripped back approximately .25 inches at the factory. To attach, push in and hold the orange tab above the socket while inserting the stripped lead. Release the orange tab and pull gently on the wire to seat it in the connector and to insure a good connection.
Note: Be careful not to push the wire too far into the socket such that the insulation is clamped by the connector.

log recorder, metering pump, or computer. The output tracks the system water conductivity. The controller is factory calibrated for 4-20mA operation. Non-standard calibration of signal is achieved by adjusting the Off-set (labeled R7) and Gain (labeled R9) potentiometers (See Fig. 10). The linearity potentiometer (labeled R12) should not be adjusted.

4. ELECTRODE REMOVAL, CLEANING, AND REINSTALLATION

A. REMOVING THE ELECTRODE

- 1) Remove power from the system.
- 2) Remove pressure by shutting hand valves on both sides of the electrode assembly (refer to Fig. 1, Typical Installation Diagram, pg. 4).
- 3) Open "flush" valve to drain water from the electrode piping. This will help removal of the electrode.
- 4) Unscrew electrode and remove electrode by pulling straight out. (See Fig. 11, Electrode)

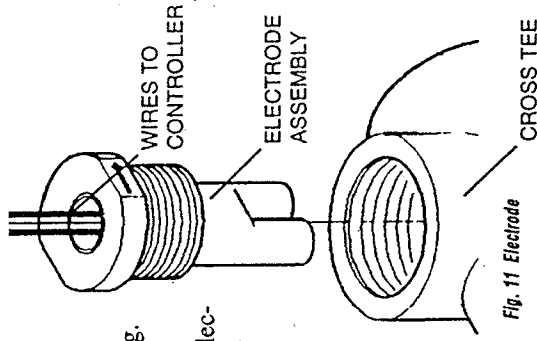

B. CLEANING ELECTRODE

- 1) Wipe the electrodes with a clean cloth. It is important to be sure to wipe the sides of the electrodes as well as the ends.
- 2) Use fine grain emery cloth for stubborn stains
- 3) Oils can affect probe performance. Do not touch probe surface. The probe can be agitated in a mild solution of dish washing soap and water to remove oils transferred during handling.
- 4) Some fouled electrodes might require dipping in a mild solution of muriatic acid to remove fouling.

NOTE: Always observe proper handling procedures when working with acids.

C. REINSTALLING ELECTRODE

- 1) Apply four wraps of pipe thread tape to the electrode threads.
 - 2) Reinstall electrode paying attention to the arrow on the electrode for direction of flow.
 - 3) Close flush valve and open hand valves to reapply pressure to the flow assembly.
- NOTE: Open hand valves slowly to avoid water hammer.**
- 4) Reapply power to the system and re-calibrate unit.

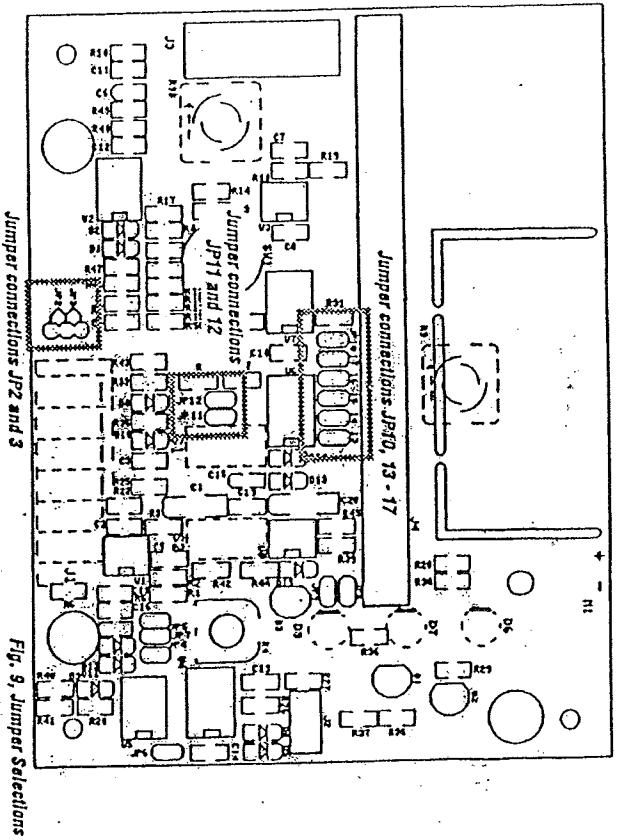

Fig. 9. Jumper Selections

JUMPER	FUNCTION	USER CHOICE
JP4,6	Selects 50 Hz. operation	Factory installed Factory installed
JP5,7	Selects 60 Hz. operation	
JP8	Selects Timed Sample Mode	Select either JP8 or JP9
JP9	Selects Continuous Sample Mode	
JP11	Selects an 8 hour time between sample intervals	Select one of JP11 - JP13
JP12	Selects a 2 hour time between sample intervals	
JP13	Selects a 30 min. time between sample intervals	
JP14	Selects a 4 min. blow down every sample interval	Select one of JP14 - JP17
JP15	Selects a 2 min. blow down every sample interval	
JP16	Selects a 1 min. blow down every sample interval	
JP17	Selects a 30 sec. blow down every sample interval	
JP2	Select for temperature compensated probe	Select either JP1 or JP3
JP3	Select for temperature non-compensated probe	

Conductivity Probe: Typically 22 AWG, 3 conductor shielded. The conductivity probe wires are color coded as follows: The probe cable length must be 3 meters or less with "V1" option.

Label Designator	Function	Probe Wire Color
RED	Probe +	Red
BLK	Probe -	Black
CLR	Probe Temp. Comp	Clear, Green or White
SHD	Probe Wire Shield	Silver (no insulation)

3. OPERATION

A. CONTROLS:

Refer to Fig. 5, Front Panel Diagram and familiarize yourself with the controls of your ABC unit.

Control LED: Used during electrode calibration and to indicate conductivity trip point has been reached. Blow down solenoid relay is active.

Power LED: Indicates unit is plugged in and power is present on the circuit board.

Cal: Calibration adjustment knob used to calibrate unit conductivity.

Test Switch: Activates solenoid relay to confirm proper operation of externally connected electrical devices (eg. blow down valve). In Timed Sample Mode, the test switch initiates the blow down cycle.

Resets optional timer.

Set/Read Switch: Set position is used to set trip point. Read position is used to monitor conductivity as measured at the electrode.

Trip Point Knob: Also referred to as "set" or "control" point. With Set/Read Switch in "Set" position, use the Trip Point knob and refer to the analog scale to set desired "trip" point to activate bleed and feed. This knob and scale is also used for calibration.

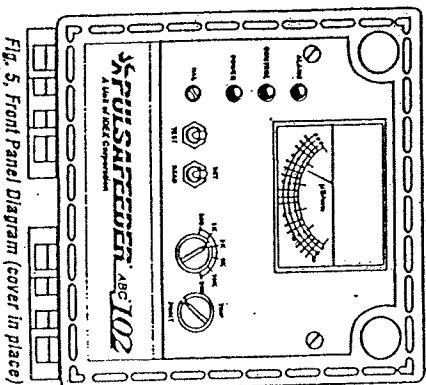

Fig. 5. Front Panel Diagram (cover in place)

Analog Scale: Used to monitor system conductivity and for calibration.
 Range Switch: Used to select either the 500, 1000, 2000, 5000, 10,000, or 20,000 $\mu\text{S}/\text{cm}$ range.

B. CALIBRATION

1) Make sure unit is mounted properly and all plumbing and electrical connections are secure. Apply power to the unit and depress the test switch to confirm proper operation of the controller and relays.

2) Take a sample of the boiler water and measure conductivity with calibrated hand held meter. Note reading (See Fig. 6, Steps 2a and 2b).

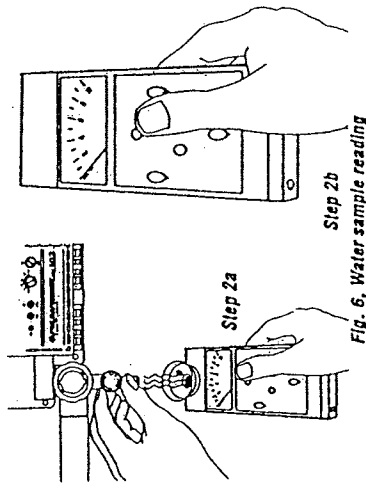

Fig. 6, Water sample reading

NOTE: Take sample at low pressure, and with water that has cooled.

- 3) Position Set/Read Switch in the "Read" position (See Fig. 7, Step 3).
- 4) Set the range switch to the correct range.
NOTE: The lower the range selected if applicable, provides more resolution.
NOTE: The range used for calibration must be the same as that to be used for control.
- 5) Adjust Cal Adjust knob until the meter on ABC matches the reading on the calibrated hand held meter. Your unit is now calibrated (See Fig. 7, Step 4).

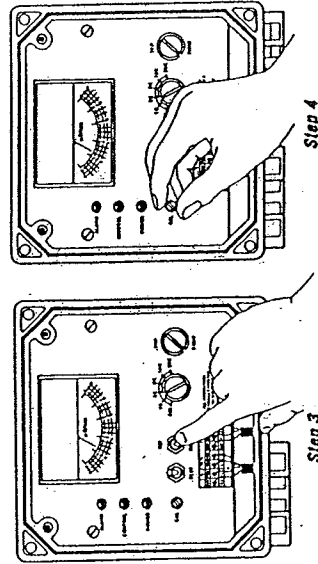

Fig. 7, System Calibration

C. SETTING CONDUCTIVITY TRIP POINT

1) With Set/Read Switch in "Set" position, turn Trip Point Knob to position needle on analog scale to desired trip point (See Fig. 8, Step 1).

2) Return the Set/Read Switch to "Read" (See Fig. 8, Step 2).

NOTE: All standard ABC units have a differential control that has been factory set to approximately 6% of the Trip Point. This important feature prevents "chattering" (the rapid on-off switching of the relay when system conductivity hovers near the trip point). The minimum blow down interval in Continuous Sample Mode is eight seconds to allow for full movement of a ball valve.

D. JUMPER SELECTIONS

The ABC controller can be operated in either Timed or Continuous Mode, the ABC controller has jumpers for selection of the operating mode and the time intervals (Fig. 9). See Jumper Table on page 10.

For Continuous Mode operation a jumper should be installed in position JP9 and JP8 should be empty.

NOTE: The minimum blow down interval in Continuous Sample Mode is eight seconds to allow for full movement of a ball valve.

For Timed Sample Mode, a jumper should be in JP8 and JP9 should be empty. The sample intervals available are 8 hours, 2 hours, and 30 minutes.

A jumper in JP11 selects 8 hours, JP12 selects 2 hours, and JP13 selects 30 minutes. Jumper only (1) one of the positions JP10 through JP13.

In the Timed Mode, there is a choice of 30 sec., 1, 2, or 4 minute blow down intervals. A jumper in JP17 selects 30 seconds, JP16 selects 1 minute, JP15 selects 2 minutes, and JP14 selects 4 minutes. Jumper only one of the positions JP14 through JP17.

NOTE: In the timed mode, the blow down interval will be at least the time selected. If conductivity is still above the selected trip point (after selected interval time has expired), blow down will continue until conductivity drops below the selected trip point.

Jumpers JP2 and JP3 are used to select operation with either a temperature compensated probe or a non-temperature compensated probe. Install a jumper in JP2 for a temperature compensated probe. Install a jumper in JP3 for a non-temperature compensated probe.

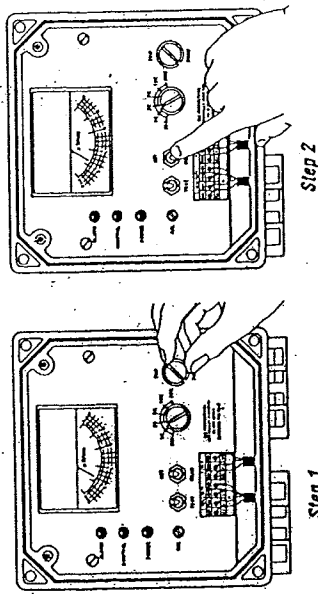

Fig. 8, Trip Point Setting