

TECHNICAL REFERENCE GUIDE

**MICROPROCESSOR – BASED WATER
TREATMENT CONTROLLER**

400 Series Programmable Timer



Table of Contents

1. INTRODUCTION	4
1.1 Description.....	4
2. INSTALLATION	6
2.1 Location	6
2.2 Installation Notes	7
2.3 Accessories (not included)	8
2.4 Electrical Wiring.....	8
2.4.1 User Connections	9
2.4.2 Hardware Settings	12
3. START UP INSTRUCTIONS	13
3.1 Power-up.....	13
3.2 Front Panel.....	14
3.3 Menu Structure	15
3.4 Key Pad Operation.....	16
3.5 Screen Format	17
3.6 Change Verification	18
3.7 Sample Programming.....	19
4. CONTROLLER SET UP.....	23
4.1 General Information.....	23
4.2 System Configure	23
4.2.1 Set Date Time:.....	24
4.2.2 Set Security:.....	24
4.2.3 Communications.....	26
4.2.4 Diagnostics	35
4.2.5 Relay Time.....	37
4.2.6 Factory Initialize.....	38
4.3 Setpoints and Alarms	39
4.3.1 Setpoints:.....	39
4.4 Timers	48
4.4.1 Selectable Timers	48
4.4.2 Water Meter Inputs.....	60
4.5 Display Data.....	65
4.5.1 Display Data: Auto Scroll Mode	65
5. DIAGRAMS: INSTALLATION, COMPONENT, AND ELECTRICAL.....	67
6. SPECIFICATIONS	75
7. FACTORY DEFAULT VALUES	77
8. TROUBLE SHOOTING GUIDE.....	79
9. MAINTENANCE	86
9.1 Flow Sensor	86
10. INTERNAL MODEM FCC COMPLIANCE INFORMATION.....	87
11. GLOSSARY	88
12. INDEX 91	
13. 28-DAY TIMER (BIOCIDE) PROGRAMMING WORK SHEET	92
14. RELAY ASSIGNMENTS	93

Conventions

For the remainder of this bulletin, the following conventions are in effect.



A WARNING DEFINES A CONDITION THAT COULD CAUSE DAMAGE TO BOTH THE EQUIPMENT AND THE PERSONNEL OPERATING IT. PAY CLOSE ATTENTION TO ANY WARNING.



Notes are general information meant to make operating the equipment easier.



Tips have been included within this bulletin to help the operator run the equipment in the most efficient manner possible. These “Tips” are drawn from the knowledge and experience of our staff engineers, and input from the field.



This is a procedure heading. A Procedure Heading indicates the starting point for a procedure within a specific section of this manual.

Standards:

The following standards have been developed to make using this manual easier. Formatting certain sections of text so that they stand out from the main body, alerts the user that there is some item of interest within a specific paragraph by drawing the users attention to:

- □ Text that has been formatted ***bold*** and ***italicized*** (e.g., ***Section 10, Maintenance***) indicates reference text.
- □ Text that is displayed using Courier as the Font type indicates a “Command String” (*DOS* text), or display window.
- □ Text that has been formatted in UPPER CASE letters, and surrounded by brackets [] indicates a button to be pressed (e.g., [ENTER]).
- □ Text that has been formatted in UPPER CASE letters, using the **Arial - Bold** Font indicates a menu selection (e.g., **CALIBRATION**).

1. Introduction

Your microprocessor based controller has been designed to function in a variety of applications where chemicals must be added at regular intervals.

This instruction manual covers the features of the standard controllers listed in *Table 1 pg. 2*.



NOTE

IMPORTANT! While using this manual, if you see instructions for a feature that does not display on your controller, check the following:

- Consult *Table 1* on the next page to see if that feature is available for your controller.
- Refer to the model number of your controller found on the enclosure of the unit. The letters after the model number are the hardware options installed.
- After the above steps, if a feature does not display, reinitialize the unit. If that fails consult the factory.

For your convenience, there is an abbreviated instruction and software “MENU MAP” laminated card supplied with all manuals to be kept with the controller. This card is not a substitute for this instruction manual. It is supplied as a quick reference only and should be used in conjunction with the instruction manual.

1.1 Description

All models include multiple Taggable Timers that allow you to choose 1 of 5 timer modes on which to base the addition of chemicals:

1. “28 DAY TIMER” The 28 DAY Timer has 4 programmable start times. It uses MONTH, WEEK, DAY, HOUR and MINUTE to define the start time. The timer will lock out all other timers when it is active.
2. “CYCLE TIMER” The Cycle Timer is used to cycle chemical feed on and off 24 hours at a time during a 28 day per month (i.e., 4 weeks) calendar basis.
3. “PULSE TIMER” The controller accepts pulses from a contacting head water meter. It activates the relay for an adjustable amount of time based on the number of pulses received.
4. “PERCENT TIMER” The Timer runs continuously for an adjustable time cycle. The timer relay is activated for an adjustable percent of the time cycle.
5. “Slaved to TIMER” Attaches any timer relay to any other relay.

An optional flow switch is available. The flow switch disables the outputs of the controller when flow is discontinued in the flow assembly.

A self charging capacitor when fully charged (usually after 24 hours operation) will maintain time and history for up to two weeks. The EEPROM protects operating parameters during power outages. Hand/Off/Auto keys are provided on the keypad for immediate control of pumps, solenoid valves, etc., without scrolling through menus.

Model 410	☞	1 Timer
Model 420	☞	2 Timers
Model 430	☞	3 Timers
Model 440	☞	4 Timers
Model 450	☞	5 Timers
Model 460	☞	6 Timers
On All Standard Models	☞	4 Single Point Drum Level connections
	☞	3 Water Meter Totalizers
	☞	1 Powered Alarm Relay
	☞	1 Dry Contact Alarm Relay
Optional On All Models	☞	Flow Sensor

Table 1 – Model Summary

2. Installation

2.1 Location

Select a mounting location convenient to grounded electrical and plumbing connections. Mount the controller on a wall or other vertical surface with adequate lighting at a comfortable level. Refer to *Section 5 – Diagram 1*, for mounting details of our standard enclosures. A mounting hole template is also provided in the literature packet supplied with your controller. Avoid locations where the controller would be subjected to extreme cold or heat. Installation should comply with all national, state and local codes.

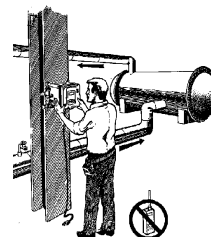

LOCATIONS WHERE THE CONTROLLER WOULD BE SUBJECTED TO EXTREME COLD OR HEAT {LESS THAN 0°F (-17.8°C) OR GREATER THAN 122°F (50°C)}, DIRECT SUNLIGHT, VIBRATION, VAPORS, LIQUID SPILLS OR EMI (ELECTROMAGNETIC INTERFERENCE; I.E., STRONG RADIO TRANSMISSION AND ELECTRIC MOTORS). THE CONTROLLER COULD BE DAMAGED AND VOID THE WARRANTY!

NOTE: NOT ALL EQUIPMENT SHOWN IS PROVIDED WITH THE CONTROLLER AND IS FOR REFERENCE ONLY.

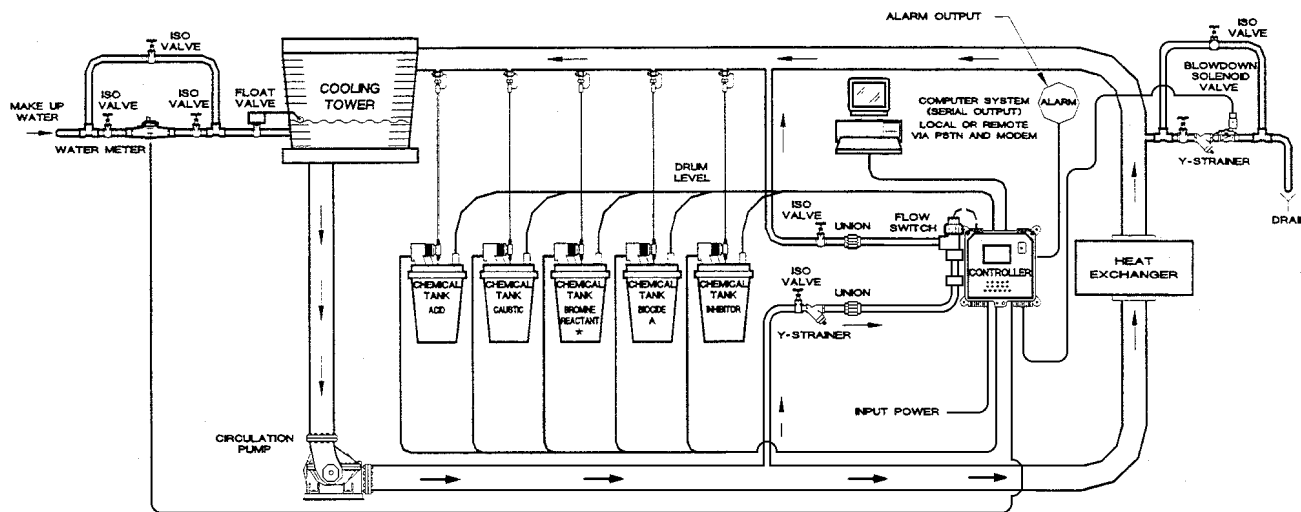

Optional flow assembly, is constructed of durable glass filled polypropylene (GFPP). Connection to the flow line is 3/4" NPT (19.05 mm). A PVC thread to slip adapter is provided so that a PVC weld joint, if preferred, can be made.

2.2 Installation Notes

1. The difference between the inlet and output pressure must be sufficient to provide a flow rate between 1 to 5 GPM (3.81 to 19.05 l/m) to assure water will flow past the sensors and they will read properly.
2. Install strainer on the upstream side of the flow assembly to collect debris that might affect controller operation. Install unions on both the inlet and outlet (see *Figure 1*).
3. Install hand valves on each side of the flow assembly for easy isolation, flow throttling, and removal of sensors and strainer screens (see *Figure 1*).
4. Direction of flow should be from the bottom to the top of the flow assembly so the flow monitoring switch will operate properly (see *Figure 2*).
5. For proper operation and accuracy, install water meters horizontally with the meter face up if the Pulse Timer mode is used.

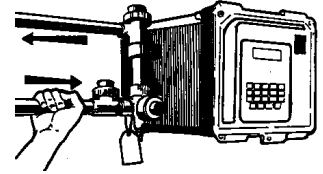

Figure 2

Hand tighten all NPT connections until snug plus 1/2 turn.

Note that a pressure differential must exist between the High and Low side for proper flow.



Water meter installation - A horizontal length equivalent to at least 12 pipe diameters must precede the water meter inlet and a horizontal pipe length of 6 diameters must follow it. All piping in this area must be of the same diameter.

2.3 Accessories (not included)

The following accessories are suggested to complete the installation.

- Two manual gate valves, one on each side of the sensor/flow assembly, to isolate the sensor/flow assembly for installation and routine maintenance.
- Three manual gate valves, for isolating, bypassing and maintenance of water meter, if controller incorporates a water meter (optional).
- Chemical metering pumps as required.
- Contacting head water meter (optional).
- External alarm.

2.4 Electrical Wiring



UNIT MUST BE WIRED IN ACCORDANCE WITH ALL APPLICABLE ELECTRICAL CODES.

The controller electronic circuitry is fuse protected (refer to *Section 5 – Diagram 7*). In addition, each output relay is individually protected by a replaceable plug-in 5 amp fuse on the relay board (refer to *Section 5 – Diagram 2*). Use of a surge protector is strongly recommended! The device should satisfy the following minimum requirements:

Response:	<1ns
Energy Dissipation:	400 Joules
EMI/RFI Noise Attenuation:	5-35dB



The controller should be connected to its own 15 amp power branch (i.e., its own wiring, circuit breaker, etc.). For best results, the ground should be independent (true earth) not shared.

Pre-wired units are supplied with 6 ft (1.8 m), 18 AWG (1.2 mm²) 3-wire grounded power cords and clearly marked 18 AWG (1.2 mm²) 3-wire grounded receptacle cords for all controlled line voltage outputs.

Conduit units are factory predrilled with easily accessible connections for hard wiring. See *Section 5 – Diagram 2*, for input and output power connections. Use only 16 AWG (1.5 mm²) or 18 AWG (1.2 mm²) wire for conduit power and load connections.

Use 22 AWG (.76 mm²) shielded wire for water meter, remote sensors, etc. Use wire provided with supplied sensors. These signal wires must be run separate from AC power lines.



Liquid Tight fittings are provided for all signal leads.

2.4.1 User Connections



When connections are required by the end user, follow the instructions below. All electrical diagrams, circuit boards, etc., are located in *Section 6*.



LINE VOLTAGE IS PRESENT ON THE POWER SUPPLY LOCATED BEHIND THE SAFETY/EMI COVER BEHIND THE FRONT PANEL. LINE VOLTAGE IS ALSO PRESENT ON THE RELAY BOARD LOCATED IN THE BOTTOM OF ENCLOSURE, EVEN WHEN POWER IS OFF. POWER MUST BE DISCONNECTED WHILE CONNECTIONS ARE BEING MADE!

2.4.1.1 Open Enclosure

1. Loosen the thumb screw on the dust cover and lift up.
2. Remove the two captive screws from upper control panel. Gently swing the panel down on its hinges.



The screws are retained and will not fall out.

2.4.1.2 Power



The controller should be connected to its own 15 amp power branch (i.e., its own wiring, circuit breaker, etc.). For best results, the ground should be independent (true earth) not shared.

Connect the incoming power to J12 on the Relay Board located at the bottom of the enclosure. Connect the Neutral to position '1' labeled 'RTN.' Connect the Earth Ground to position '2' labeled with the earth ground symbol. Connect the Line to position 3 labeled 'HOT.' Use only 16 AWG (1.5 mm²) wire.

The control circuit is fuse protected (refer to *Section 5 – Diagram 7*). In addition, each output relay is individually protected by a replaceable plug-in 5 amp fuse on the relay board (refer to *Section 5 – Diagram 2*).

Use of a surge protector is strongly recommended! The device should satisfy the following minimum requirements:

Response:	<1ns
Energy Dissipation:	400 Joules
EMI/RFI Noise Attenuation:	5-35dB

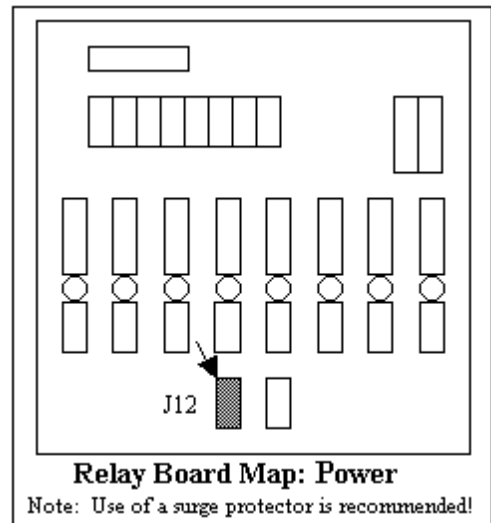

2.4.1.3 Relay Connections

Relay connections are made to J3, J4, J5, J6, J7, J8 and J9. Use only 16 or 18 AWG (1.5mm² or 1.22mm²) wire. Both normally open and normally closed powered contacts are available. To complete the wiring, first locate your model number (refer to **Table 1 – pg. 2**). Then note the relay positions and associated functions. Wire your blowdown device (e.g., motorized ball valve) to the appropriate position. Note all outputs are powered at line voltage and fused at 5A. Many motorized ball valves require connections to both the Normally Open (NO) and Normally Closed (NC) terminals. Refer to **Section 5 – Diagram 2**, for further wiring details.

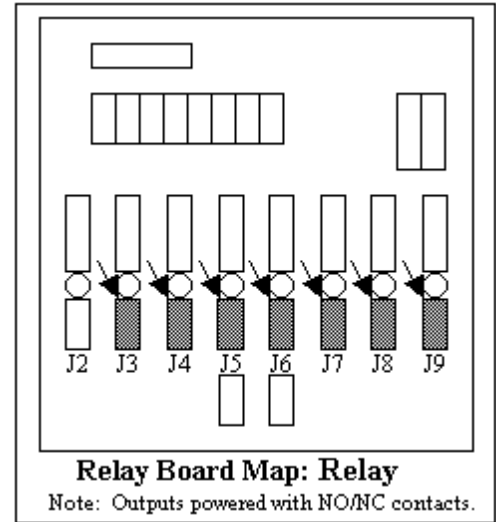

2.4.1.4 Flow Switch or Interlock

It is recommended that a flow switch or auxiliary dry contact from the control panel be used to make outputs inoperative when the cooling tower is shut down. This connection is provided on all standard units.

To use the interlock feature, connect a flow switch or auxiliary dry contact from another device. Refer to **Section 5 – Diagram 2**, for flow switch or interlock connection location (connections are position 11 and 12 labeled FLOW SWITCH).

To activate this function:

3. Turn the power switch off.
4. Turn switch S1-”2” on.

This switch is located on the mother board (refer to **Section 5 – Diagram 3**).

5. Wait 15 seconds, and turn power back on.

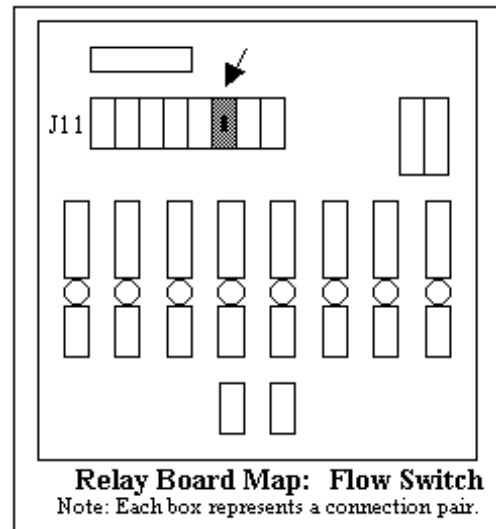

2.4.1.5 Water Meter (for Pulse Timer)

Electrical wiring is not required for water meters. A pigtail is provided with labeled leads for connection to your dry contacting head water meter.

The pigtail is connected to the Relay Board at the bottom of the enclosure. Refer to *Section 5 – Diagram 2*, for the water meter connection location. The connections are made to J11. Connect water meter #1 to positions 13 and 14. Connect water meter #2 to positions 15 and 16. Connect water meter #3 to positions 9 and 10.

The Controller can be configured with one or more (model dependent) water meters driving one or more pulse timers. The association is made in the software not hardware. Refer to *Controller Setup* for further information.

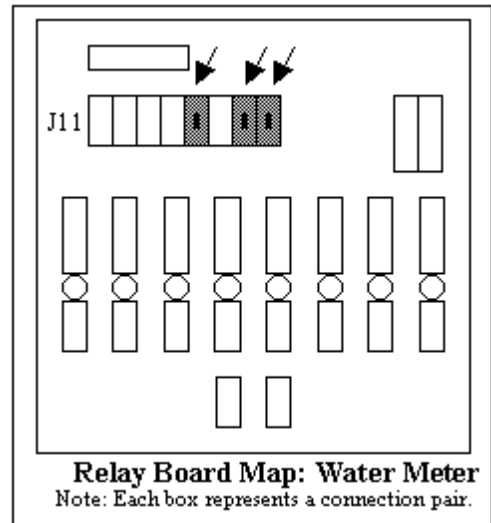

2.4.1.6 Drum Level

Electrical wiring is not required for single point drum level sensors. A pig tail is provided with the appropriate connectors for wand style sensors. See *Section 5 – Diagram 8*.

The pigtail is connected to the Relay Board at the bottom of the enclosure. Refer to *Section 5 – Diagram 2*, for the drum level connection location. The connections are made to J11 positions 1, 2, 3, 4, 5, 6, 7, and 8 on the Relay Board.

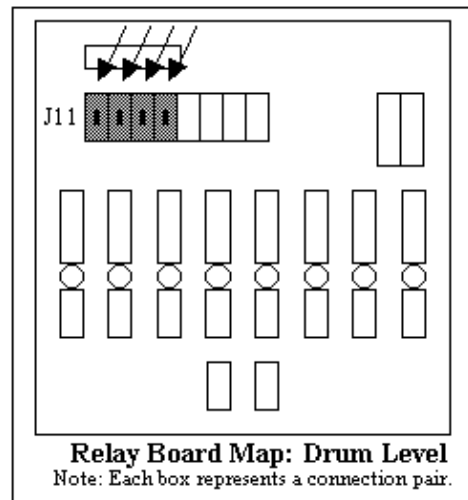

2.4.1.7 Alarm Dry Contact

Alarm dry contacts (rated @ 500 mA) are standard. A labeled pigtail with two normally open contacts is provided.

The pigtail is connected to the Relay Board at the bottom of the enclosure. Refer to *Section 5 – Diagram 2*, for the Alarm Dry Contact connection location (connections are made to J1 positions 1, 2, 3 and 4).

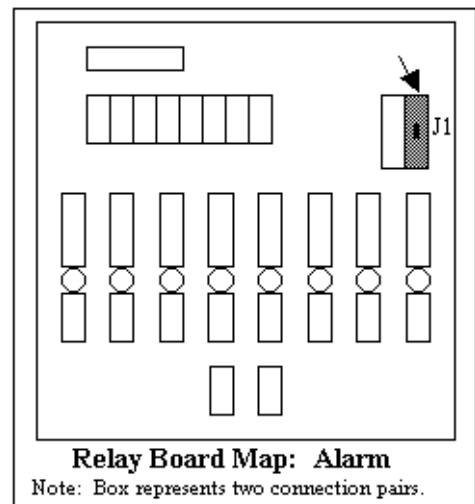

2.4.1.8 Receptacles

The Controller offers a unique pre-wired package as standard. Each cord is clearly marked and readily accessible for connecting external electrical devices to be controlled.

A conduit option is available. Refer to *Section 5 – Diagram 2*, for wiring.

2.4.2 Hardware Settings

The default hardware settings for your controller will satisfy a majority of cooling tower installations. Review the default operating ranges listed in the table below. If you expect to operate outside of the stated range, check the ‘User Setting?’ column to see if you can change the setting. If you can (YES), refer to the associated page listing for jumper / switch setting diagrams and instructions.

Input/Output Description	Default Setting	User Setting?
Power Supply (In)	90-250 VAC, 50/60 Hz	NO
Flow Switch	ON (if flow assembly supplied)	YES
Serial Communications	RS-232	NO
Single Point Drum Level	Closed = Low Level	NO

3. Start Up Instructions

READ THE FOLLOWING BEFORE PROCEEDING ANY FURTHER!!

3.1 Power-up



BEFORE APPLYING POWER, INSURE THAT DEVICES BEING CONTROLLED ARE NOT IN A POSITION TO CAUSE HARM OR DAMAGE IF ACTIVATED UPON INITIAL START-UP.

1. With the controller now installed in a convenient location, supply power to the controller and turn the Logic Power switch on.

The power LED indicator light will be illuminated.

A **PLEASE WAIT** screen is displayed briefly followed by the **SYSTEM WARMING UP** screen.

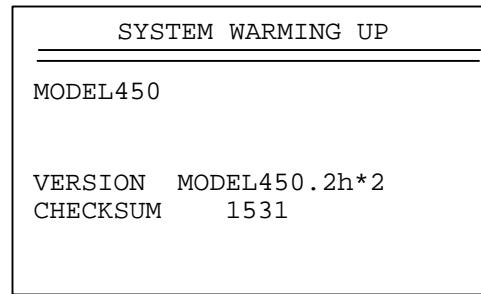
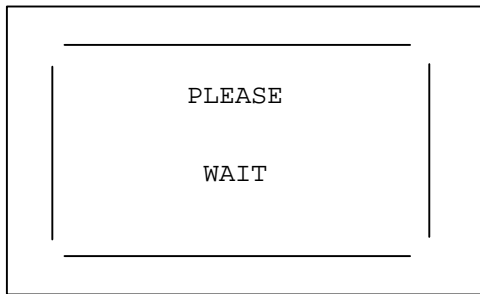

During warming up, the controller performs internal diagnostics.

When the diagnostics check is complete, the **MAIN MENU** is displayed.

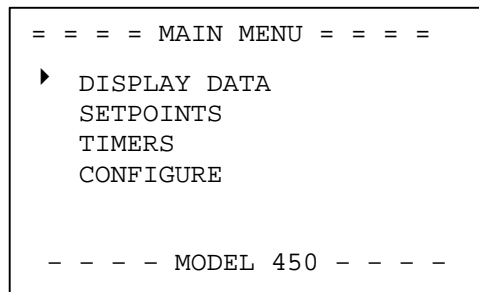

The results of the Diagnostic check is repeated in the Configure/Diagnostics menu. Refer to *Section 4 – Diagnostics*.

3.2 Front Panel

Take a moment to review *Figure 4*, to become familiar with the controller front panel.

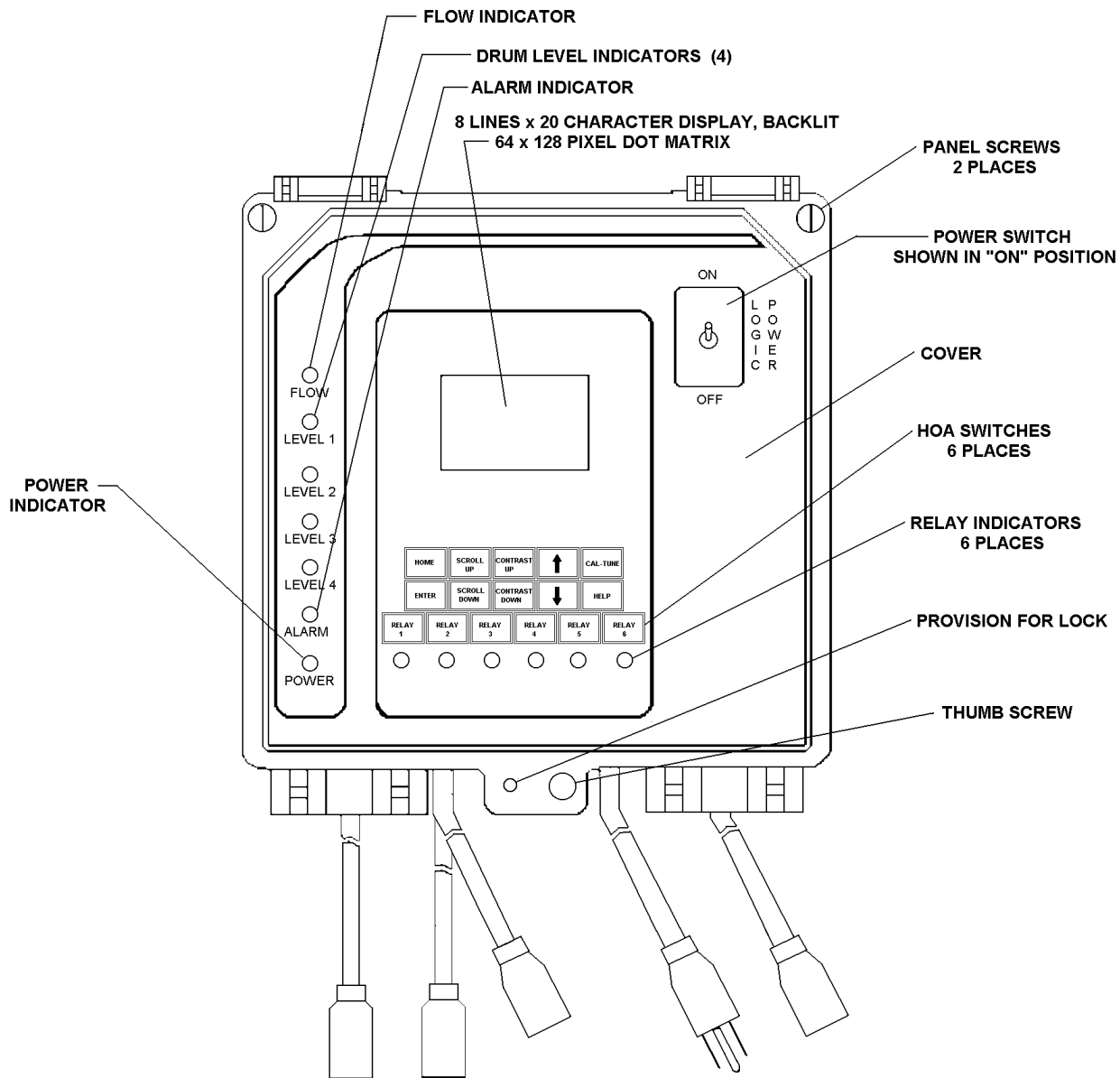
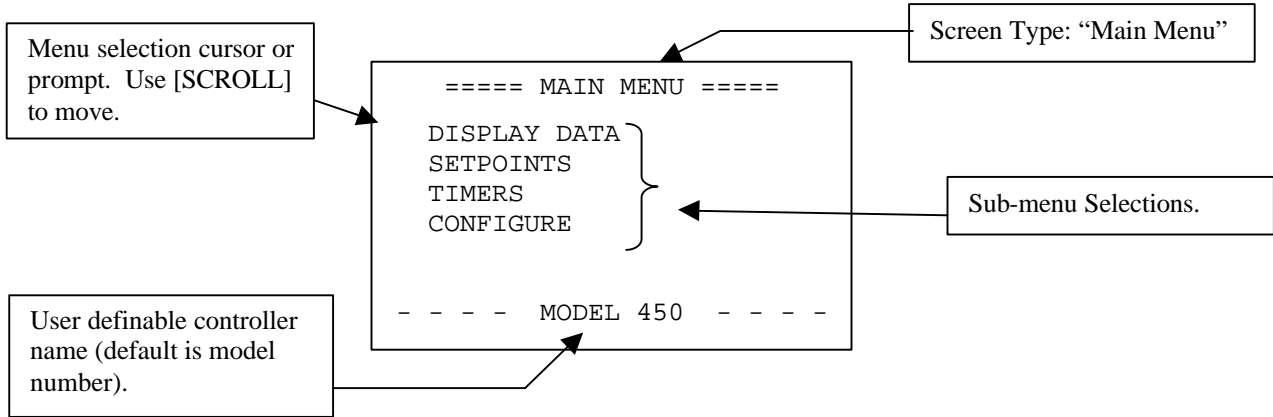

Figure 4 – Front Panel

3.3 Menu Structure

The Controller’s menu structure is designed to be user friendly. The **MAIN MENU** structure diagram shows the first level of all sub-menus in the controller. Not all sub-menus shown here may be present on your controller. The laminated “MENU MAP” supplied with the controller reflects your specific system with options.



TIP

For help with menu locations, please refer to the “Menu Map” supplied with your controller.

- **Display Data** – Displays date, time, week number, software version, system alarms, and relay on times. After five minutes of no keypad activity, the controller will start to scroll through the display data screens automatically. It is possible to lock any of the display data screens to display continuously. This menu displays information only. No settings or adjustments are made through this menu.
- **Set Points** – In this menu you are prompted to enter settings pertaining to set points that control the system’s operation and associated alarms.
- **Timers** – In this menu, you are prompted to enter settings pertaining to the Timers. You can select between five different timer types.
- **System Configure** – This is generally the first selection made at start up. In this menu, you are prompted to configure system functions and options to your specific application. System Configure includes such things as time of day, date, security, communications, diagnostics, relay on time and factory re-initialization.

3.4 Key Pad Operation

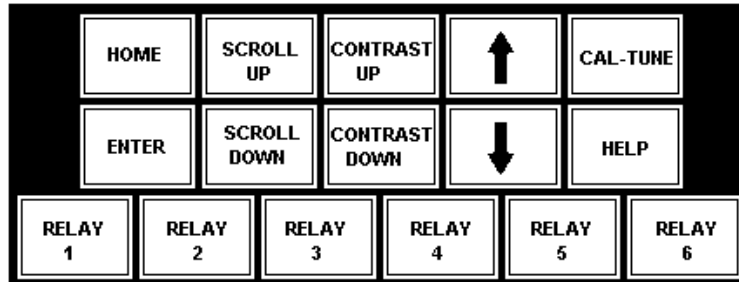

The Key Pad is easy to use and will guide you through the sub menus and functions of the controller.

Feel free to try out these keys as you read about them. You will not hurt the controller and the values will need to be reprogrammed later anyway.

- **HOME** – Press [HOME] to return to the previously displayed menu. Press [HOME] to exit an edit field. Press [HOME] to reject a setting.
- **SCROLL UP/SCROLL DOWN** – Press [SCROLL] to move the triangular cursor or “prompt” to the next line.
- **CONTRAST UP/CONTRAST DOWN** – Press [CONTRAST] to control the contrast of the viewing screen. Pressing [UP] will darken the display, pressing [DOWN] will lighten it.
- **ARROWS** – The Arrow keys are used to change the numbers or values associated with the various settings you will be entering. Use [DOWN] to select lower numbers and [UP] to select higher numbers.



When using the Arrow Keys, press once to change the number by one unit.

- **ENTER** – Enter has three functions:
 1. After moving the prompt using the [SCROLL] key to a menu choice, press [ENTER] to display the sub menu of the choice you selected.
 2. (Within the sub menu), after moving the prompt with [SCROLL] to the selection of your choice, press [ENTER] to edit the selection (the prompt will disappear and the value to be changed will reverse - **a white character is displayed against a black background**).



NEVER LEAVE A SCREEN IN THE MIDDLE OF EDITING A FIELD! CONTROLLER ACCURACY MAY BE AFFECTED, AND/OR THE CONTROLLER MAY NOT OPERATE PROPERLY. IF YOU FORGET, SIMPLY RETURN TO THAT MENU AND COMPLETE YOUR PROGRAMMING.

3. After changing/selecting the value needed with [UP] / [DOWN] press [ENTER] to “lock-in” the value. The prompt and value selected will appear normal.

- **CAL-TUNE** –The key has no function on this model series.
- **HELP** – When pressed, this key will display simple instructions for the operation of the [ENTER], [HOME], [ARROW], and [SCROLL] keys.
- **RELAYS (1-6)** – These Hand/Off/Auto (HOA) keys allow immediate control of the relays powering attached pumps, solenoid valves, etc. Press a [RELAY] key once to force the relay on for 5 minutes (an amber light is displayed below that key). Press the [RELAY] key again to force the relay off (a red light is displayed below that key, relay will be forced off until the key is pressed again or the power is cycled on the unit). Press the [RELAY] key a third time to return the relay to auto control (green light will indicate that relay is on, no light indicates that relay is off).

3.5 Screen Format

The controller screens are formatted in a manner that will help you understand what you can and cannot do.

- **Value Field: “RUN TIME = 01:30”**
A line on the screen with an “=” sign means that you may change the value. If a line were to read “RUN TIME = 01:30” then you will be able to change the RUN TIME duration one position at a time (hour and minutes).
- **List Field: “TYPE: 28 DAY”**
A line that has a “:” means that you can change a value by selecting from a list. For example “TYPE : 28 DAY” means that you will be able to select from a list of values: **disabled, 28 DAY, CYCLE, PULSE, PERCENT**, and **Slaved to**.
- **Sub-Menu Field: “<PROGRAMS>”**
A line that has a word surrounded by “<” and “>” means that there is a sub-menu. To access the sub-menu, move the prompt to the line and press [ENTER].

The following is a sample screen that demonstrates all 3 field types:

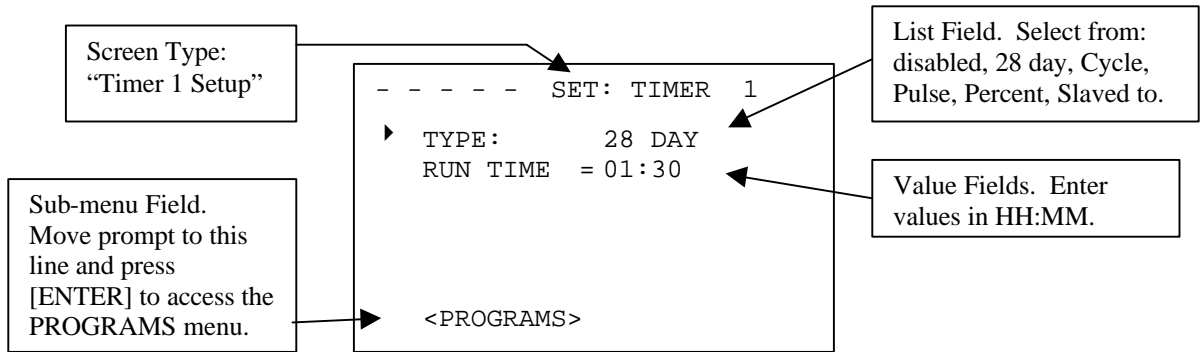

3.6 Change Verification

Whenever you make changes to a menu on your controller, a change verification screen appears when you leave that menu. To accept your changes, press [ENTER]. To reject your changes press [HOME].

```

    - - SYSTEM CHANGES - -
      HAVE BEEN MADE !

    ?? SAVE CHANGES ??

    Press ENTER to SAVE
    Press HOME to ABORT
    
```

When you accept your changes, the value will be changed and the previous menu will be displayed. When you reject your changes, the menu values will be restored to their original values and the menu will be re-displayed. Press [HOME] to exit the menu.

3.7 Sample Programming

The following is a detailed example of how to program your controller. Once you have mastered this exercise, you will be ready to set up the controller to your specifications.



IMPORTANT! Please note that in all programming instructions, *keypad instructions* are presented as all capitals—“[ENTER]”. Items as they *appear in the display* are presented as all capitals and bold face — “**DISPLAY DATA**.”

For this exercise, you will set “**DAY, WEEK, DATE, and TIME.**”

1. If not already displayed, press the [HOME] key until **MAIN MENU** is displayed. Then use the [SCROLL] key to move prompt to **CONFIGURE**.

```

-----MAIN MENU-----
DISPLAY DATA
SETPOINTS
TIMERS
▶ CONFIGURE
- - - - MODEL 450 - - - -
    
```

Press [ENTER] to display the **CONFIGURE** menu

```

-----CONFIGURE-----
▶ DATE TIME
SECURITY
DIAGNOSTICS
RELAY TIME
FACTORY INITIALIZE
    
```

2. With prompt on the **DATE TIME** line press [ENTER] to display the **DATE TIME** menu.

```

-----DATE TIME-----
▶ TIME    = 11:07
DATE     = 05-Aug-2000
DAY      = THU
WEEK     = 1st

Values are frozen
    
```

3. With prompt on the **TIME** line press [ENTER].

```
-----DATE TIME-----
▶ TIME   = 11:07
  DATE   = 05-Aug-2000
  DAY    = THU
  WEEK   = 1st

Values are frozen
```

4. You are now editing a “Value” field. The prompt will disappear and the first digit (1 in this case) is displayed with a black background. You are now editing just this one position in the time setting (24 hour format). Use the [ARROW] keys to change the value. Press [ENTER] to accept the value and move to the next position. Repeat this process until you have set the current time. Press [ENTER] on the last position (7 in this case) and the prompt will return at the left side of the screen.

```
-----DATE TIME-----
TIME   = 11:07
DATE   = 05-Aug-2000
DAY    = THU
WEEK   = 1st

Values are frozen
```

5. Press [SCROLL] to move the prompt to the **DATE** line.

```
-----DATE TIME-----
TIME   = 11:07
▶ DATE   = 05-Aug-2000
  DAY    = THU
  WEEK   = 1st

Values are frozen
```



Be sure to press keys firmly until you feel or hear a faint click, then pause before you try again. There is a very slight delay for the controller to react to your command. This is normal.

- Press [ENTER]. The prompt will disappear and the first digit (0 in this case) is displayed as white text on a black background. Again, just like you did in Step 4, use the [ARROW] keys to change the value and the [ENTER] key to move the edit box. Press [ENTER] on the last position (0 in this case) and the prompt will return to the left side of the screen.

```

-----DATE TIME-----
TIME   = 11:07
DATE   = 05-Aug-2000
DAY    = THU
WEEK   = 1st

Values are frozen
    
```

- Press [SCROLL] to move the prompt to the **DAY** line

```

-----DATE TIME-----
TIME   = 11:07
DATE   = 05-Aug-2000
▶ DAY  = THU
WEEK   = 1st

Values are frozen
    
```

- Press [ENTER]. The prompt will disappear and the entire day field is displayed as white text on a black background. You are now editing a “List” field. Use [UP] / [DOWN] to display values in the list. In this case the values will be: **MON, TUE, WED, THU, FRI, SAT** and **SUN**. When the correct day is displayed, press [ENTER] to accept. The prompt will return to the left side of the screen.

```

-----DATE TIME-----
TIME   = 11:07
DATE   = 05-Aug-2000
DAY    = THU
WEEK   = 1st

Values are frozen
    
```



If at any time, while programming your controller, you get lost or confused, press the [HOME] key repeatedly until you get back to the Main Menu and start again.

9. Press [SCROLL] to move the prompt to the **WEEK** field

```
-----DATE TIME-----  
TIME    = 11:07  
DATE    = 05-Aug-2000  
DAY     = THU  
▶ WEEK  = 1st  
  
Values are frozen
```

10. Press [ENTER]. Again the prompt will disappear and the entire week field is displayed as white text on a black background. Again you are editing a “List” field. Use [UP] / [DOWN] to display the values in the list: **1st, 2nd, 3rd** and **4th**. When the correct week is displayed, press [ENTER] to accept. The prompt will return to the left side of the screen.

```
-----DATE TIME-----  
TIME    = 11:07  
DATE    = 05-Aug-2000  
DAY     = THU  
WEEK    = 1st  
  
Values are frozen
```

11. Repeat any of the Steps 3 to 10 above until you are satisfied with your settings.
12. Press [HOME] to exit the **DATE TIME** screen. A confirmation screen is displayed.

```
-----SYSTEM CHANGES-----  
HAVE BEEN MADE !  
  
??  SAVE CHANGES  ??  
  
PRESS  ENTER  TO SAVE  
PRESS  HOME   TO ABORT
```

If you are satisfied with your settings press [ENTER] to save them.

If you want to abandon your settings and revert to the original values press [HOME].

Congratulations, you’ve done it! Now, press [HOME] repeatedly until the **MAIN MENU** is displayed.

4. Controller Set Up

4.1 General Information



BEFORE APPLYING POWER, INSURE THAT DEVICES BEING CONTROLLED ARE NOT IN A POSITION TO CAUSE HARM OR DAMAGE IF ACTIVATED UPON INITIAL START-UP.

With the controller now installed in a convenient location, apply power and turn the power switch on. The power LED indicator light will illuminate. When the controller is powered up, the **PLEASE WAIT** and **SYSTEM WARMING UP** screens are displayed until the internal diagnostics tests are complete, then the **MAIN MENU** is displayed.

```
-----MAIN MENU-----  
  
▶ DISPLAY DATA  
  SETPOINT  
  TIMERS  
  CONFIGURE  
  
- - - - MODEL 450 - - - -
```

If the display contrast requires adjustment, use [CONTRAST UP] or [CONTRAST DOWN] keys on the control panel key pad to adjust the screen for best viewing.

The default values for all control features have been factory set, but you will want to fine tune the controller to meet your specific application.



WHEN POWER IS SUPPLIED TO THE UNIT, LINE VOLTAGE IS PRESENT ON THE RELAY BOARD LOCATED IN THE BOTTOM OF THE ENCLOSURE EVEN WITH THE LOGIC POWER SWITCH OFF.

4.2 System Configure

Configure the controller functions using the [SCROLL] keys to move the prompt to **CONFIGURE** on the **MAIN MENU**. Press [ENTER] and the **CONFIGURE MENU** will be displayed. If the security system has been activated, see the TIP on the next page.

```
----- CONFIGURE -----  
  
▶ DATE TIME  
  SECURITY  
  COMMUNICATIONS  
  DIAGNOSTICS  
  RELAY TIME  
  FACTORY INITIALIZE
```

4.2.1 Set Date Time:

1. Please refer to *Section 3.7 – Sample Programming*.
2. When completed press [HOME] once to return to **CONFIGURE**.

4.2.2 Set Security:

The Controller can be configured to have two Security Access Codes - a Master and a User. The Master level can access all functions of the controller. The User level can only access those **MAIN MENU** items selected by the Master. A password level is not required for access to the **DISPLAY DATA** menu item. The Master Password is required to enter the **CONFIGURE** menu.



When the password system is active, you will be prompted to enter a password. Press [ENTER] and use the [ARROW] keys to set each digit of your password - use [ENTER] to move between digits. Press [HOME] to return to the **MAIN MENU**. Then press [ENTER] to enter the menu item you have selected. If the [ENTER] **PASSWORD** screen re-appears, the password you entered was not accepted or you have not been granted access to that menu.

The following is the Security screen with the major components labeled:

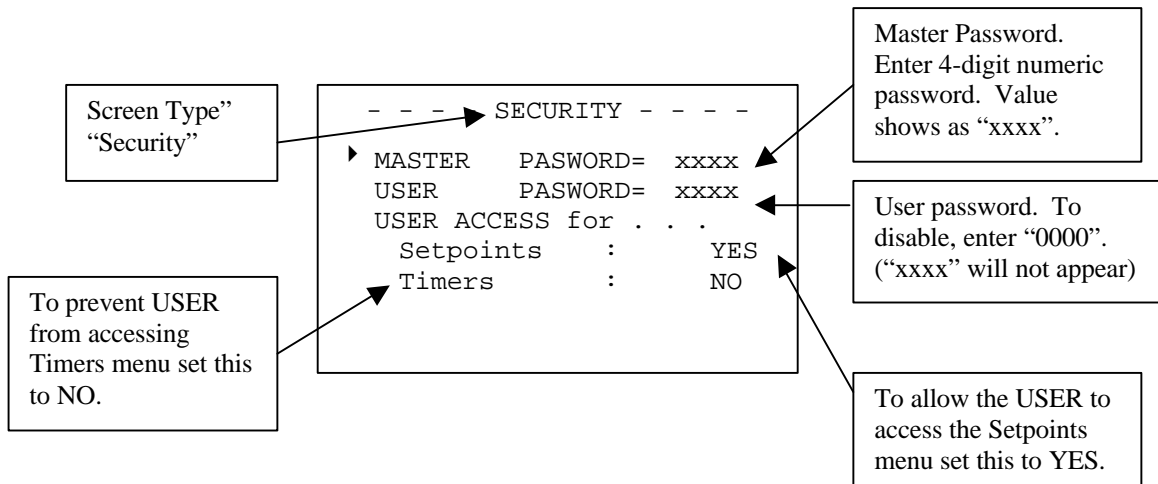

To configure security on your controller follow this procedure:

1. Use the [SCROLL] keys to move the prompt to **SECURITY** and press [ENTER]. The **SECURITY** sub-menu is displayed.

```

- - - SECURITY - - -
▶ MASTER PASSWORD=
  USER PASSWORD=
  USER ACCESS for . . .
    Set points   :   NO
    Timers       :   NO
    
```

2. Use the [SCROLL] keys to move the prompt to “**MASTER PASSWORD=**”. Press [ENTER].
3. Use the [UP] / [DOWN] keys to set each digit. Press [ENTER] to move to the next digit. Before you press [ENTER] on the last digit, check the value you have entered. Write it down if necessary! When you press [ENTER] on the last digit, the prompt will re-appear and your entry will be displayed as “xxxx”.

```

- - - SECURITY - - -
  ▶ MASTER PASSWORD= 1000
USER PASSWORD=
USER ACCESS for . . .
  Calibration : NO
  Set points : NO
  Timers : NO
  Data Collect : NO
    
```

4. Use the [SCROLL] keys to move the prompt to **USER PASSWORD** level. Repeat step 3 for the **USER PASSWORD**.
5. Use the [SCROLL] keys to move the prompt to the **USER ACCESS for . . . SETPOINTS** line. Press [ENTER]. Use [UP] / [DOWN] to set the access to the **SETPOINTS** menu to “**YES**” or “**NO**”.

```

- - - SECURITY - - -
  ▶ MASTER PASSWORD= xxxx
  USER PASSWORD= xxxx
  USER ACCESS for . . .
    Setpoints: YES
    Timers: NO
    
```

6. If set to “**YES**”, the USER will be allowed to access this sub-menu from the **MAIN MENU** when the security system is active. If set to “**NO**”, the **MASTER PASSWORD** will be required for access. Press [ENTER] to accept your value. The prompt will return to the left side of the screen.
7. Repeat step 5 to set access for the **TIMERS** menu.
Once you have successfully entered a password it will allow access until the controller has not detected a key press for 5 minutes. If the unit is automatically scrolling through the **DISPLAY DATA** screens, then the 5 minute timer has expired and you will have to re-enter your password to gain access to the sub-menus.



TIP

To disable the security system, enter a password of “0000” for both the **MASTER** and **USER** levels. To activate the security system immediately (after entering a password), enter the **DISPLAY DATA** menu and unlock the display (press [ENTER]).

4.2.3 Communications

Use the **COMMUNICATIONS** sub-menu to configure parameters associated with the Serial Communications system.



The **COMMUNICATIONS** sub-menu is active on all models regardless of whether you purchased a communications option with your controller. If you did not purchase the option, you can change the settings, but they will have no effect on the operation of your controller.

The following figure labels the major components of the **COMMUNICATIONS** menu.

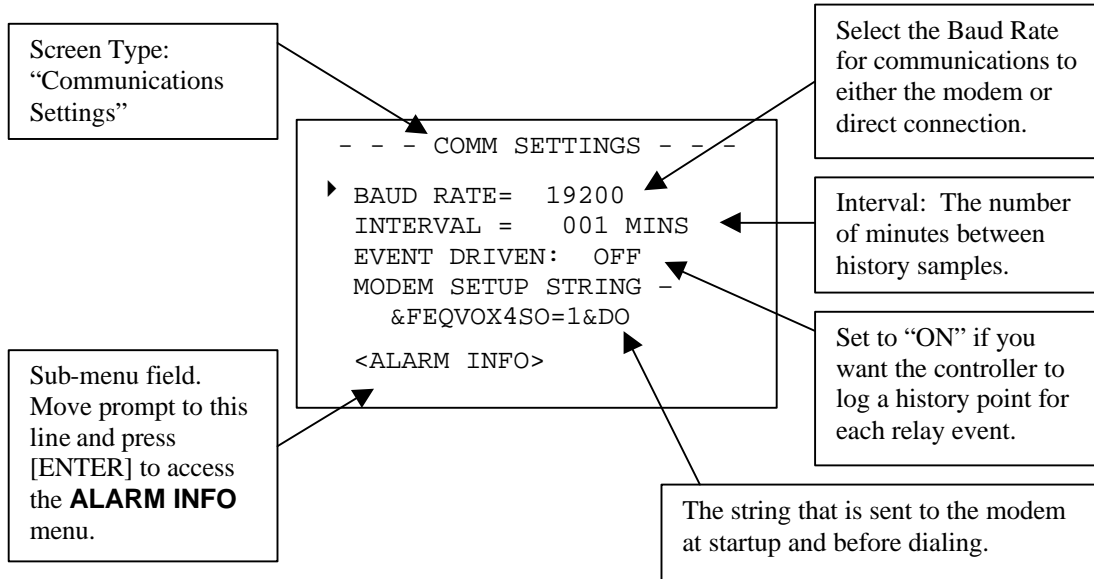

Use this procedure to set-up serial communications on your controller:

1. Use the [SCROLL] keys to move the prompt to **COMMUNICATIONS** on the **CONFIGURE** menu. Press [ENTER]. The **COMMUNICATIONS** menu is displayed.

```

- - - CONFIGURE - - -
  DATE TIME
  SECURITY
  ▶ COMMUNICATIONS
  DIAGNOSTICS
  RELAY TIME
  FACTORY INITIALIZE
    
```

```

- - COMMUNICATIONS - -
  ▶ SETTINGS
  ALARM CALLBACK

  QUICK TESTS
    
```

2. **SETTINGS** is the default selection. Press [ENTER]. The **COMM SETTINGS** menu is displayed.

```

- - COMM SETTINGS - -
▶ BAUD RATE:  19200
  INTERVAL = 001 MIN
  EVENT DRIVEN:  OFF
  MODEM SETUP   STRING
  &FE0V0X4S0=1&DO

<ALARM>
    
```

3. With the prompt next to **BAUD RATE**, press [ENTER]. Use [UP] / [DOWN] to select from the list of baud rates: **300, 1200, 2400, 9600, 14400, 19200, 28800** or **57600**. Select the default value (**19200**) for best results when using the internal modem or performing a direct connection. Press [ENTER] after making your selection.

```

- - COMM SETTINGS - -
▶ BAUD RATE:  19200
  INTERVAL = 001 MIN
  EVENT DRIVEN:  OFF
  MODEM SETUP STRING
  &FE0V0X4S0=1&DO

<ALARM>
    
```



When connecting the controller directly to a PC, the baud rate settings must match or the connection will fail.

4. Move the prompt to **INTERVAL**. Press [ENTER]. Using [UP] / [DOWN] / [ENTER] set the interval rate, in minutes, at which the history will be collected. You can set this value between 1 and 120 minutes.

```

- - COMM SETTINGS - -
  BAUD RATE:  19200
▶  INTERVAL = 001 MINS
  EVENT DRIVEN:  OFF
  MODEM SETUP STRING -
  &FE0V0X4S0=1&DO

<ALARM INFO>
    
```



The controller will hold approximately 372 data points. At an interval of 1 minute, you will have to download your controller every 6 hours to avoid missing data points. At an interval of 120 minutes you will only have to download it once a month.

5. Move the prompt to **EVENT DRIVEN**. Press [ENTER]. Using [UP] / [DOWN] / [ENTER] select either **YES** or **NO**. If you select **YES**, history will be collected every time an event (i.e., a change in the relay status) occurs on the controller regardless of the **INTERVAL** setting. This allows you to capture exact times and values when major events occur.

Normally, when using this mode you would set the **INTERVAL** to a large value (e.g., 060 MIN).

6. Move the prompt to the line below **MODEM SETUP STRING** which reads **&FE0V0X4S0=1&D0** on the example screen shown below. This item displays the current modem setup string and allows you to edit the current setting. Press [ENTER]. Using [UP] / [DOWN] / [ENTER] set the modem setup string value one character at a time. Move the prompt to the **MODEM SETUP STRING** line and press [ENTER]. The new string is sent immediately to the serial port and/or modem.

```
- - COMM SETTINGS - -  
BAUD RATE: 19200  
INTERVAL = 001 MINS  
EVENT DRIVEN: OFF  
MODEM SETUP STRING  
▶ &FE0V0X4S0=1&D0  
<ALARM INFO>
```



We strongly recommend that you do not change the MODEM SETUP STRING. The default setting is designed for use with the supplied modem. Use of non-standard modems and/or setup strings will not be supported by the Technical Services group.

7. Move the prompt to **<ALARM INFO>** and press [ENTER] to display the **HISTORY 80%** setup window. If the history on the controller is 80% full (i.e., you are about to lose history), you can have the controller activate a number of alarm states. Move the prompt to **Alarm LED**. Press [ENTER]. Using [UP] / [DOWN] / [ENTER] set the **Alarm LED** value to **YES** if you want the front panel **LED** to flash when this alarm occurs. Likewise, set the **Alarm RELAY** to **YES** if you would like the alarm relay to come ON with the alarm and the **Alarm CALLBACK** to **YES** if you would like the system to perform an alarm callback. Press [HOME] to exit this window.

```
- - - - ALARM INFO - - - -  
HISTORY 80%  
▶ Alarm LED: YES  
Alarm RELAY: YES  
Alarm CALLBACK: NO
```

8. If you made changes on the **ALARM INFO** window, you will be prompted to save your changes. Press [ENTER] to accept your changes and exit the window. Press [HOME] to abort your changes and remain in the window with the previous values. In this case, press [HOME] again to return to the previous **COMM SETTINGS** menu.

9. You should now be back at the **COMM SETTINGS** menu. Press [HOME] to return to the **COMMUNICATIONS** menu. If you have made changes on the **COMM SETTINGS** window you will be prompted to save or abort your settings.

```

- - SYSTEM CHANGES - -
      HAVE BEEN MADE !

?? SAVE CHANGES ??

Press ENTER to SAVE

Press HOME to ABORT
    
```

10. Press [SCROLL] to move the prompt to the **ALARM CALLBACK** selection. Press [ENTER] to access the **ALARM CALLBACK** menu.

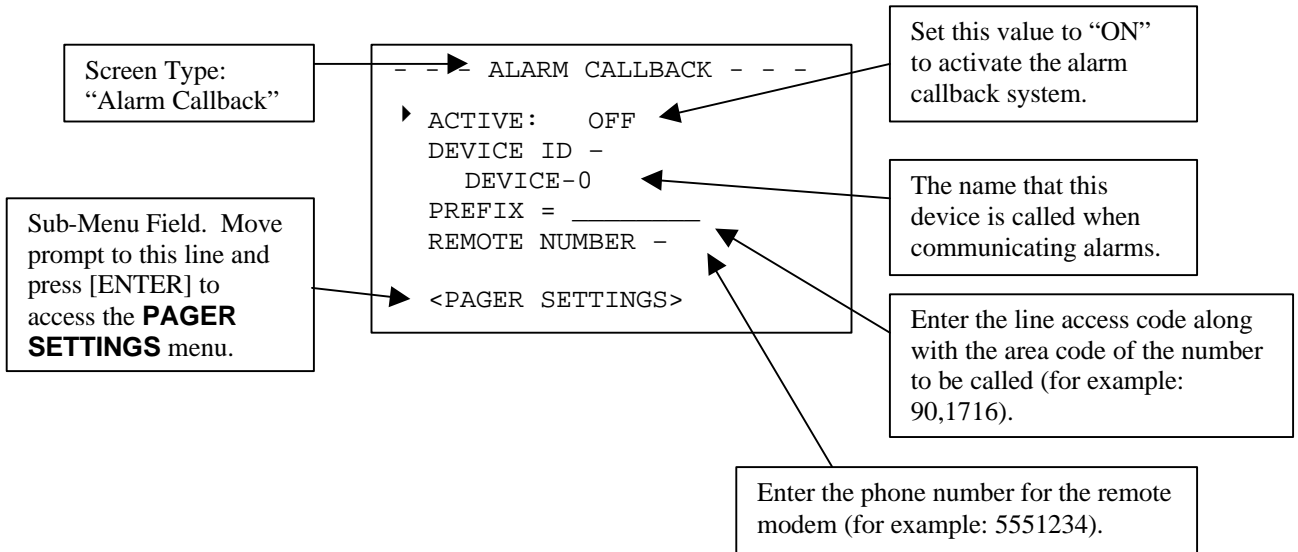

11. Press [SCROLL] to move the prompt to the **ACTIVE** entry. Use [UP] / [DOWN] / [ENTER] to change the value to **YES** if you would like the **ALARM CALLBACK** system to be active.



NOTE

While you are setting up the alarm call back system, you should set active to "NO" to prevent the controller from acting on incomplete entries. After setup is complete, set active to "YES".

```

- - ALARM CALLBACK - -

▶ ACTIVE: NO
  DEVICE ID
    TEST 1234
  PREFIX = _____
  REMOTE NUMBER
    5551234
  <PAGER SETTINGS>
    
```

12. Press [SCROLL] to move the prompt to **DEVICE ID**. Use [UP] / [DOWN] / [ENTER] to change the **DEVICE ID** one character at a time. The **DEVICE ID** is the name that will be transmitted to your PC when calling out on an alarm.
13. Press [SCROLL] to move the prompt to **PREFIX**. Press [ENTER]. Use [UP] / [DOWN] / [ENTER] to change the value one character at a time. The **PREFIX** is the number that is used to give access to an “outside” phone line and also includes the area code of the number to be called. Your telephone service configuration will determine what is required to get to an “outside” line (e.g., some systems require pressing 9 and 0, while some systems only require that you press 9). The **PREFIX** field can be left blank if the call is a local call.
14. Press [SCROLL] to move the prompt to **REMOTE NUMBER**. Use [UP] / [DOWN] / [ENTER] to change the value one character at a time. The **REMOTE NUMBER** is the phone number of the PC that will receive the alarm callback. The alarm must remain active for 1.5 minutes before the controller will dial this number.



TIP

You can use a comma (,) in the phone number entry to cause the modem to pause one second. This is useful when you must dial “90”, then wait for a dial tone before proceeding (e.g. 90,,17162928000)

15. Move the prompt to the **<PAGER SETTINGS>** line and press [ENTER] to display the **PAGER SETTINGS** menu.
16. Press [ENTER] to enter **PAGER NUMBER**. Use [UP] / [DOWN] / [ENTER] to change the pager **PREFIX** number one character at a time. When the last number in the prefix has been entered, press [ENTER] until the prompt is displayed on the left side of the screen.

```

- - PAGER SETTINGS - -
▶ PREFIX = 90,1716__
  PAGER NUMBER -
    2928000
  PAGER ID -
    ,1,2,3,001*?#-
  ALARM CODE = 27
    
```

17. Press [SCROLL] to move the prompt to **PAGER NUMBER**. Use [UP] / [DOWN] / [ENTER] to change the pager phone number one character at a time. When an alarm remains active for 5 minutes the controller will dial this number and then the Pager ID Number.

```

- - PAGER SETTINGS - -
  PREFIX = _____
▶ PAGER NUMBER -
  90,17162928000
  PAGER ID -
    ,1,2,3,001*?#-
  ALARM CODE = 27
    
```



NOTE

The controller will dial the pager number only one time. It will redial the remote number up to five times. Consult your communications software documentation for set-up and use of the alarm call back system.

CALL 1-800-577-8111 FOR SALES AND SUPPORT

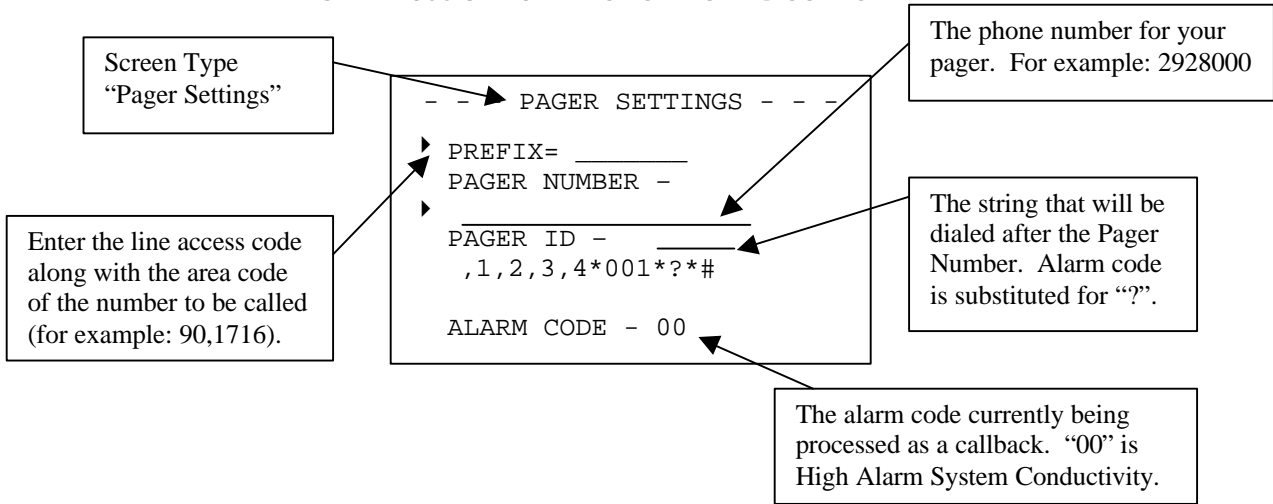

18. Press [SCROLL] to move the prompt to **PAGER ID**. Use [UP] / [DOWN] / [ENTER] to set the string that will identify this controller on your pager. The "?" is replaced with the alarm code. If the controller had a high Conductivity Alarm (alarm code = 00), the pager message would look like "001-00-".
19. Press [HOME] to return to the **ALARM CALLBACK MENU**. Press [HOME] again to return to the **COMMUNICATIONS** menu. Press [HOME] again to return to the **MAIN MENU**.

4.2.3.1 Quick Tests

An additional menu item has been added to the Serial Communications menu called Quick Tests. The Quick Tests menu allows you to test your modem and alarm callout (to another modem) or alarm page (to your pager). The menu shows test progress and diagnostics information. You access the **QUICK TESTS** menu from the **COMMUNICATIONS** menu. This menu is formatted as follows:

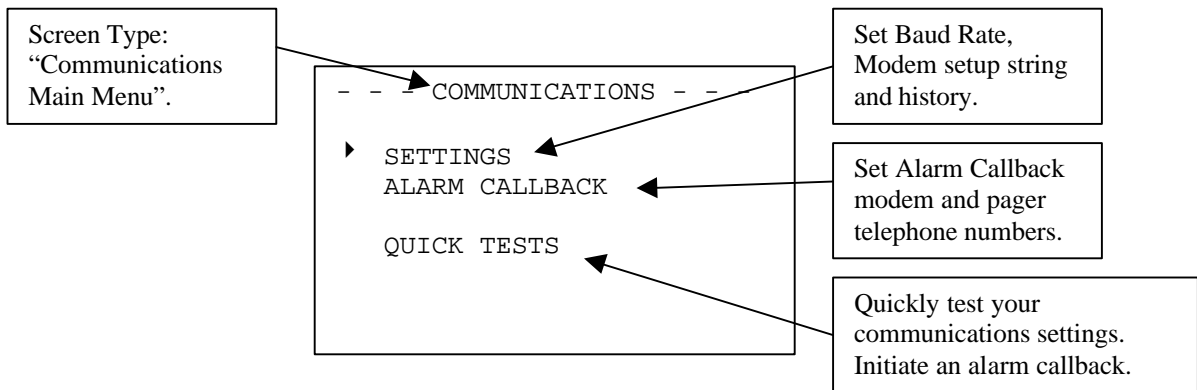

To access the **QUICK TESTS** menu, move the prompt to the **QUICK TESTS** selection and press [ENTER]. The **Quick Tests** menu is formatted as follows:

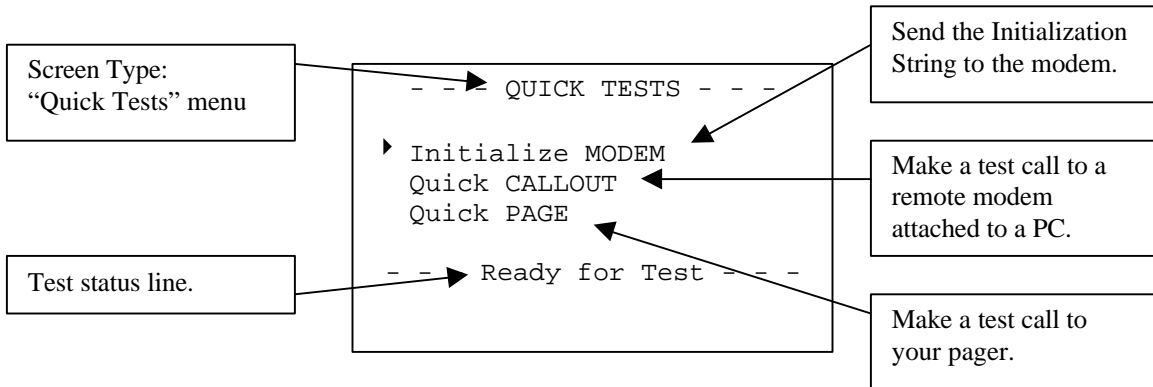

Using the QUICK TESTS menu:

1. Press [HOME] repeatedly to return to the **MAIN MENU**. Press [SCROLL] to move the prompt to **CONFIGURE** and press [ENTER]. The **CONFIGURE** menu is displayed.
2. Press [SCROLL] to move the prompt to **COMMUNICATIONS** and press [ENTER]. The **COMMUNICATONS** menu is displayed.
3. Confirm that you have the Alarm Callback system set up. Press [SCROLL] to move the prompt to **ALARM CALLBACK**. Press [ENTER]. The **ALARM CALLBACK** menu is displayed.
 - a) To test the **ALARM CALLBACK**, you must have a phone number in the **REMOTE NUMBER** field.
 - b) To test **PAGING**, you must have a pager number in the **PAGER NUMBER** field.
 Press [HOME] to return to the **COMMUNICATIONS** menu.



Important: Before leaving the **ALARM CALLBACK** menu, set the **ACTIVE: setting to off.**

4. Press [SCROLL] to move the prompt to **QUICK TESTS** and press [ENTER]. The **QUICK TESTS** menu is displayed.

```

- - - QUICK TESTS - - -

▶ Initialize MODEM
Quick CALLBACK
Quick PAGE

!!! NOT READY !!!
    
```

5. The **QUICK TESTS** menu allows you to test the serial communications system and validate its operation. It includes helpful information that can help you isolate problems with your modem or Alarm Callout/Paging system. If you do not desire to test your modem, skip to step 7. Otherwise, use [SCROLL] to move the prompt to **Initialize MODEM**.

6. Observe the bottom line of the display. It should read '**- Ready for Test -**'. If it reads '**!!! NOT READY !!! XX**' and is displaying a count-down value ('XX' in the example) wait for the count down period. If it reads '**** ACB Active ****' then the **ALARM CALLBACK** system is active. Return to step 3 and verify that the **ACTIVE:** setting is set to **OFF**. Wait for the callout to complete or eliminate all alarm sources. When the display reads '**--- Ready for Test --**', you can begin testing the desired item.



NOTE

You cannot perform a quick test while you are communicating with the controller. The controller must not receive any characters on its serial port for 20 seconds before a quick test can be performed. If a device is communicating with your controller, the count-down value will be re-set to 20 every time a character is received.

7. Press [SCROLL] to move the prompt to **Initialize MODEM**. Press [ENTER] to start the **Initialize MODEM** test. The line at the bottom of the display will read '***** TESTING *****' to indicate that a test is in progress. The line above this gives test status information. The controller will first attempt to communicate (initialize) the modem. If the modem is present and properly configured, it will respond to this attempt with the word '**OK**'. It will then send the Modem Setup String. If this string is accepted the modem will again respond with the word '**OK**'. If the test fails, an error message will be displayed (e.g., Timed Out). Refer to *Section 8 – Trouble Shooting Guide*, for further information.

```

- - - QUICK TESTS - - -

  Initialize MODEM
    Quick CALLOUT
    Quick PAGE

  Initializing
    *** TESTING ***
```

8. To test the alarm callout feature of the controller, move the prompt to the **Quick CALLOUT** selection. Press [ENTER]. The controller will initialize the modem, dial the phone number and attempt to connect an external PC running a communications package. The status is displayed above the '***** TESTING *****' line. The following would be a typical response of the status line. First '**Initializing...**' is displayed while the controller sends the setup string to the modem. Then '**OK**' is displayed if the modem responds to the setup string. The '**Dialing 18885551234**' is displayed as the modem dials the phone number. Once a connection has been made the '**CONNECT XXXX**' line is displayed. Finally, the '**Operation Complete**' message is displayed indicating that the operation completed correctly. The controller then hangs up the phone line and a '**No Carrier**' message is displayed on the screen. Refer to *Section 8 – Trouble Shooting Guide*, for further diagnostic information.



NOTE

You must have entered proper phone numbers for the CALLOUT and PAGING in the Alarm Call Back system for the quick tests to function properly.

9. To test the paging callout capabilities of the controller, move the prompt to the **Quick PAGE** selection. Press [ENTER]. The controller will initialize the modem, dial the phone number, issue the alarm string, then hang-up the phone line. First '**Initializing...**' is displayed while the controller sends the setup string to the modem. Then '**OK**' is displayed if the modem responds to the setup string. The '**Dialing 18885551234**' is displayed as the modem dials the phone number. The '**Operation Complete**' message is displayed, indicating the

controller has completed the page call out. Refer to *Section 8 – Trouble Shooting Guide*, for further diagnostic information.



NOTE

If you set the **ALARM CALL BACK ACTIVE**: setting to “OFF”, be sure to set it back to “ON” after you have completed your quick test.

10. Press [HOME] repeatedly to return to the **MAIN MENU**.

4.2.4 Diagnostics

This section lets you see how the inputs (i.e., key presses or water meter pulses) and outputs (i.e., display and LED's) are working and view internal diagnostics results for your controller. Normally, on power-up, the controller tests its internal EPROM (the device that holds the program that allows your controller to function), the RAM (the device that holds your history and other temporary system settings), the EEPROM (the device that holds your more permanent settings) and the Real Time Clock.

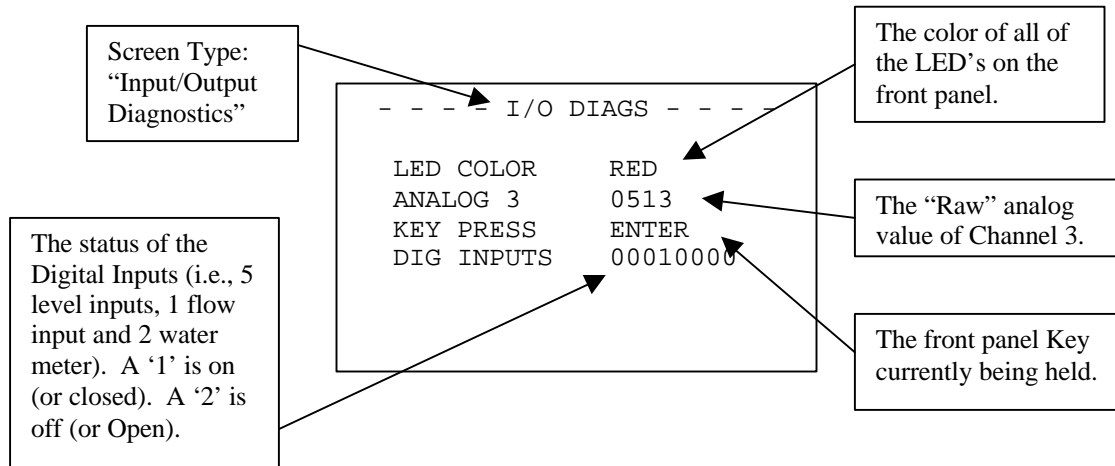

1. Move the prompt to the **I/O DIAGNOSTICS** line and press [ENTER].

```

- - - DIAGNOSTICS - - -
▶ I/O DIAGNOSTICS
  MEMORY DIAGNOSTICS
    
```



WARNING WHEN RUNNING I/O DIAGNOSTICS ALL CONTROL WILL CEASE.

The **I/O DIAGS** menu is displayed. When you enter this menu, you will note that all of the LED's begin to illuminate.

```

- - - I/O DIAGS - - -
LED COLOR      GREEN
ANALOG 2      0438
KEY PRESS      none
DIG INPUTS     00000101
    
```

In addition, they begin to cycle through their colors (RED, GREEN, YELLOW, OFF). The **LED COLOR** menu item indicates the current color. The **ANALOG N** item will change approximately every second. It will cycle through numbers where N is a value between 1 and 8. These values represent the analog input channels. For example, Channel 1 is typically **SYSTEM CONDUCTIVITY**. The number shown next to the channel number is the raw analog value for the displayed channel. It will be in a range between 0 and 1023. The **KEY PRESS** item indicates which key is currently pressed. If you press any key (with the exception of [HOME] which will take you out of the **I/O DIAGS** menu) the description is displayed here for as long as you hold that key down. The **DIG INPUTS** represents the current status of the **DIGITAL INPUT** hardware. The field displays 8 digits, each of which has a value of 1 or 0. The positions correlate to the digital inputs on the J11 connector of the Relay board. The display will show a '1' if the input is closed and a '0' if it is open. For example, if the only digital input is **FLOW** and the flow is currently ON then the display would appear like this: **00000100**. When flow is OFF, the display would look like this: **00000000**.



Un-used analog channels typically “float”. Their value is unpredictable. Do not be alarmed if you see a value here for a channel in which there is no installed hardware. This is normal.

2. Press [HOME] to return to the **DIAGNOSTICS** menu.

```

- - - DIAGNOSTICS - - -
I/O DIAGNOSTICS
▶ MEMORY DIAGNOSTICS
    
```

3. Press [SCROLL] to move the prompt to **MEMORY DIAGNOSTICS**. Press [ENTER]. The **MEMORY DIAGS** menu is displayed. The results of the last power-on test is displayed. If any items failed the diagnostics test, the number of failures and first failure address is displayed.

```

- - - MEMORY DIAGS - - -
start-up results
RAM    FAULTS - 0000
      1st ADDRESS - none
EEPROM FAULTS - 0000
      1st ADDRESS - none
CLOCK          - OK
    
```

4. Press [HOME] to return to the **DIAGNOSTICS** menu. Press [HOME] again to return to the **CONFIGURE MENU**.

```

- - - - CONFIGURE - - - -
DATE TIME
SECURITY
▶ DIAGNOSTICS
RELAY TIME
FACTORY INITIALIZE
    
```

4.2.5 Relay Time

This menu allows you to reset the relay on times that appear in the **DISPLAY DATA: RELAY** screen. It also records a date time stamp to indicate when the relay on times were last reset.



For help with menu locations, please refer to the “Menu Map” supplied with your controller.

1. From the **CONFIGURE MENU**, press [SCROLL] to move the prompt to **RELAY TIME**. Press [ENTER]. The **RELAY TIME** menu is displayed. Use this menu item to zero the relay ON times reported on the **DISPLAY DATA: RELAY TIME** window.

```

- - - RELAY TIME - - -
▶ ZERO TIME
  LAST ZEROED AT -
    01/01/2000 08:01
    
```

2. Press [ENTER] to zero the relay ON times. The line below the **LAST ZEROED AT** heading shows the date and time the relays were last zeroed.
3. Press [HOME] to return to the **CONFIGURE MENU**.

```

- - - - CONFIGURE - - - -
DATE TIME
SECURITY
COMMUNICATIONS
DIAGNOSTICS
RELAY TIME
▶ FACTORY INITIALIZE
    
```

4.2.6 Factory Initialize

You can re-initialize your controller to its factory settings.

1. From the **CONFIGURE MENU**, press [SCROLL] to move the prompt to **FACTORY INITIALIZE**. Press [ENTER]. The **FACTORY INIT** menu is displayed.

```

- - - FACTORY INIT - - -

▶ INITIALIZE to
  FACTORY DEFAULTS

<ALARM INFO>
    
```

2. Press [ENTER] to begin Factory Initialization.



WHEN INITIALIZING OR RE-INITIALIZING YOUR CONTROLLER, ALL OF THE SYSTEM SETTINGS WILL BE OVERWRITTEN BY THE ORIGINAL FACTORY DEFAULT SETTINGS. THE CONTROLLER MUST THEN BE RECONFIGURED TO YOUR SPECIFICATIONS.

3. A warning screen is displayed.

```

- - - FACTORY INIT - - -

FACTORY ReINIT WILL
OVERWRITE ALL
PREVIOUS SETTINGS

Press ENTER to ReINIT
Press HOME to ABORT
    
```

Press [ENTER] to continue the initialization, press [HOME] to abort. If you continue with initialization, the display will blank and the system will re-start.

4. If you aborted the initialization, the **FACTORY INIT** menu is displayed. Press [SCROLL] to move the prompt to **<ALARM INFO>**. Press [ENTER]. The **ALARM INFO** screen is displayed for the **INIT ALARM**. When the controller has started from a factory re-initialization, the items that you indicate here will activate.

```

-- - ALARM INFO - - -
      INIT ALARM

▶ Alarm LED:          YES
  Alarm RELAY:       YES
  Alarm CALLBACK:    YES
    
```

5. Press [HOME] to return to the **FACTORY INIT** menu. Press [HOME] again to return to the **CONFIGURE MENU**. Press [HOME] one more time to return to the **MAIN MENU**.

4.3 Setpoints and Alarms

4.3.1 Setpoints:

4.3.1.1 SETPOINTS: Level (Single Point)

Level Inputs are designed to operate with dry contact switching devices (e.g., float style level switch). They can be configured to operate with a switch that produces a continuous signal (e.g., a float switch turns on when the level is low), or an alternating one (e.g., a flow monitor generating a pulse every 2 seconds when the pump is operating). Level Inputs can be configured to activate the **Alarm LED**, activate the **Alarm RELAY** and/or initiate an **Alarm CALLBACK** event. Each input can be configured independently. The first 4 inputs (J11 positions 1 to 8 on the relay board) also illuminate the 4 LED positions (Level 1 - 4) between the **FLOW** and **Alarm LED**'s on the left side of the front panel. These LED's turn **RED** when the contact is closed (provided **ACTIVE** is set to closed) and **GREEN** when it is open. The inputs are configured with an adjustable de-bounce delay.



Procedure for setting the single point LEVELS:

1. From the **SETPOINTS** menu, move the prompt to **LEVEL #** (where # is the Level Number). Press [ENTER]. The **LEVEL #** menu is displayed.

```

----- SETPOINTS -----
▶ LEVEL 1
  LEVEL 2
  LEVEL 3
  LEVEL 4
  FLOW
    
```

```

----- LEVEL 1 -----
▶ TYPE      :    LEVEL
  ACTIVE    :    Closed
  TIME      =    5.00 Sec

<RELAY LINKS>
<ALARM INFO>
    
```

2. On the second line of the screen, the usage **TYPE** field is displayed. If necessary press [SCROLL] to move the prompt to the **TYPE** line. Press [ENTER].
3. Use [UP] / [DOWN] to select between **LEVEL** and **FLO MONITOR**. Proceed to *Section 4.3.1.1.2, Setpoints: Level (FLO MONITOR)* if **FLO MONITOR** is selected.

4.3.1.1.1 Setpoints: Level (LEVEL)

When **TYPE** is set to **LEVEL**, the input is treated as a standard single point drum level. When the input activates (e.g., closes) any relays that are selected in the **<RELAY LINKS>** menu are turned off and the configured alarms are activated.



Procedure for setting the Setpoints: Level (Level)

1. Press [SCROLL] to move the prompt to the **ACTIVE** line. Press [ENTER] and the switch status is highlighted.

```

----- LEVEL 1 -----
TYPE      :    LEVEL
▶ ACTIVE  :    Closed
TIME      =    5.00 Sec

<RELAY LINKS>
<ALARM INFO>
    
```

```

----- LEVEL 1 -----
TYPE      :    LEVEL
ACTIVE    :    Closed
TIME      =    5.00 Sec

<RELAY LINKS>
<ALARM INFO>
    
```

Press [UP] / [DOWN] to alternate between **Closed** or **Open**. The **ACTIVE** setting indicates the non-alarming condition of the switch input. Press [ENTER] to accept your selection.

2. Press [SCROLL] to move the prompt to the **TIME =** line.

```

----- LEVEL 1 -----
TYPE      :    LEVEL
ACTIVE    :    Closed
▶ TIME    =    5.00 Sec

<RELAY LINKS>
<ALARM INFO>
    
```

Press [ENTER] to enter the **TIME** field.

When the **TYPE** field is set to **LEVEL**, the **TIME** field is used to configure the duration of the de-bounce delay. In other words, this field determines how long the contact must remain active before the input is recognized.

```

----- LEVEL 1 -----
TYPE      :    LEVEL
ACTIVE    :    Closed
TIME      =    05.00 Sec

<RELAY LINKS>
<ALARM INFO>
    
```

The **TIME =** field is a four-digit field. If a single digit setting was used (5.00 seconds in the example above), when the **TIME** field is entered, a 0 is displayed to the left of the 5. The fourth digit will not “hold” an entered value unless the value is less than 1 second.

3. Use [UP] / [DOWN] and [ENTER] to set each digit in the **TIME =** field. Pressing [ENTER] on the fourth digit enters the de-bounce delay setting into the system.

4. Press [SCROLL] to move the prompt to the **<RELAY LINKS>** line.

```

----- LEVEL 1 -----
TYPE      :    LEVEL
ACTIVE    :    Closed
TIME      =    5.00 Sec

▶ <RELAY LINKS>
  <ALARM INFO>
    
```

5. Press [ENTER] to open the **<RELAY LINKS>** screen.

```

----- LINK LEVEL 1 -----
▶ RETURN TO DEFAULT
  RELAY 1          NO
  RELAY 2          NO
  RELAY 3          NO
  RELAY 4          NO
  RELAY 5          unused
  RELAY 6          unused
    
```

When the field is set to **LEVEL** from the **LEVEL 1** menu, the **<RELAY LINKS>** menu allows you to select relays that the level input will turn off when it activates.

6. Press [SCROLL] to move the prompt. When the prompt is next to the desired relay (e.g., **RELAY 3**), press [ENTER]. Use [UP] / [DOWN] to select between **NO** (do not turn the relay off) and **YES** (turn the relay off). Press [ENTER] to accept your selection. Press [HOME] to return to the **LEVEL 1** menu.



To return the LINK page to the default settings, move the prompt to RETURN TO DEFAULT and press [ENTER].

7. Press [SCROLL] to move the prompt to the **<ALARM INFO>** line

```

----- LEVEL 1 -----
TYPE      :    LEVEL
ACTIVE    :    Closed
TIME      =    5.00 Sec

  <RELAY LINKS>
▶ <ALARM INFO>
    
```

- Press [ENTER] to open the **<ALARM INFO>** screen.

```

----- ALARM INFO -----
                LEVEL 1
▶ Alarm LED:      YES
  Alarm RELAY:   YES
  Alarm CALLBACK: YES
    
```

- Use [UP] / [DOWN] and [ENTER] to set the values for **Alarm LED**, **Alarm RELAY** and **Alarm CALLBACK** to either **YES** or **NO**.



Setting the **LED** value to **NO** on the **ALARM INFO LEVEL** menu will not disable (i.e., turn off) the level LED on the front panel. It will only prevent the Alarm LED from flashing given a **LEVEL** condition.

- Press [HOME]. Follow the on-screen prompt (i.e., **SYSTEM CHANGES HAVE BEEN MADE!** menu).

4.3.1.1.2 Setpoints: Level (FLO MONITOR)

When set to **FLO MONITOR**, the input is monitored for the active condition (e.g., closed) over the time interval (e.g., 5 sec.) This condition is checked whenever the relays specified in the **<RELAY LINKS>** are active.



Procedure for setting the Setpoints: Level (FLO MONITOR)

- Press [SCROLL] to move the prompt to the **ACTIVE** line. Press [ENTER] and the switch status is highlighted.

```

----- LEVEL 1 -----
TYPE      :   FLO MONITOR
▶ ACTIVE   :   Closed
TIME      =   .04 Sec
DELAY     =   00:10 M:S

<RELAY LINKS>
<ALARM INFO>
    
```

Press [UP] / [DOWN] to alternate between **Closed** or **Open**. The **ACTIVE** setting indicates the condition of the switch input that will indicate a flow pulse (e.g., closed means the switch will close every time the pump discharges fluid).

```

----- LEVEL 1 -----
TYPE      :   FLO MONITOR
ACTIVE    :   Closed
TIME      =   .04 Sec
DELAY     =   00:10 M:S

<RELAY LINKS>
<ALARM INFO>
    
```

CALL 1-800-577-8111 FOR SALES AND SUPPORT

Press [ENTER] to accept your selection.

2. Press [SCROLL] to move the prompt to the **TIME =** line.

```
----- LEVEL 1 -----
TYPE      :      FLO MONITOR
ACTIVE    :      Closed
▶ TIME    =      .04 Sec
DELAY     =      00:10 M:S

<RELAY LINKS>
<ALARM INFO>
```

Press [ENTER] to enter the **TIME** field.

The **TIME =** field sets the amount of time the switch must be active (open or closed) to be recognized. Typically, a flow pulse from a solenoid driven pump can be recognized with the default setting of .04 seconds.

```
----- LEVEL 1 -----
TYPE      :      FLO MONITOR
ACTIVE    :      Closed
TIME     =      00.04 Sec
DELAY    =      00:10 M:S

<RELAY LINKS>
<ALARM INFO>
```

3. Use [UP] / [DOWN] and [ENTER] to set each digit in the **TIME =** field. Pressing [ENTER] on the fourth digit enters the setting into the system.
4. Press [SCROLL] to move the prompt to the **DELAY=** line.

```
----- LEVEL 1 -----
TYPE      :      FLO MONITOR
ACTIVE    :      Closed
TIME     =      .04 Sec
▶ DELAY   =      00:10 M:S

<RELAY LINKS>
<ALARM INFO>
```

5. Press [ENTER] to enter the **DELAY=** field.

```
----- LEVEL 1 -----
TYPE      :      FLO MONITOR
ACTIVE    :      Closed
TIME     =      .04 Sec
DELAY    =      00:10 M:S

<RELAY LINKS>
<ALARM INFO>
```

The **DELAY=** field is used to set the amount of time to delay before issuing an alarm. You would normally set this to a time greater than the interval between flow pulses. For example, if you are using a pump with a maximum frequency of 125 SPM and you have its stroke rate setting at 12%, then the pump will stroke every 4 seconds $[60/(125 \times .12) = 4]$. The delay should be set at a value of 4 seconds or greater.

6. Use [UP] / [DOWN] and [ENTER] to set each digit in the **DELAY=** field. Pressing [ENTER] on the fourth digit enters the setting into the system.
7. Press [SCROLL] to move the prompt to the **<RELAY LINKS>** line.

```

----- LEVEL 1 -----
TYPE      :      FLO MONITOR
ACTIVE    :      Closed
TIME      =      .04 Sec
DELAY     =      00:10 M:S

▶ <RELAY LINKS>
  <ALARM INFO>
    
```

8. Press [ENTER] to open the **<RELAY LINKS>** screen.

```

----- LINK LEVEL 1 -----
▶ RETURN TO DEFAULT
  RELAY 1          NO
  RELAY 2          NO
  RELAY 3          NO
  RELAY 4          NO
  RELAY 5          unused
  RELAY 6          unused
    
```

The **<RELAY LINKS>** menu allows you to select relays that will be monitored. When the selected relay is active the FLO MONITOR input will expect pulses at the specified interval, otherwise it will activate the programmed alarm.

9. Press [SCROLL] to move the prompt. When the prompt is next to the desired relay (e.g., **RELAY 3**), press [ENTER]. Use [UP] / [DOWN] to select between **NO** (do not turn the relay off) and **YES** (turn the relay off). Press [ENTER] to accept your selection. Press [HOME] to return to the **LEVEL 1** menu.



To return the LINK page to the default settings, move the prompt to RETURN TO DEFAULT and press [ENTER].

10. Press [SCROLL] to move the prompt to the **<ALARM INFO>** line.

```

----- LEVEL 1 -----
TYPE      :      FLO MONITOR
ACTIVE    :      Closed
TIME      =      .04 Sec
DELAY     =      00:10 M:S

  <RELAY LINKS>
▶ <ALARM INFO>
    
```

- Press [ENTER] to open the **<ALARM INFO>** screen.

```

----- ALARM INFO -----
                LEVEL 1
▶ Alarm LED:      YES
Alarm RELAY:     YES
Alarm CALLBACK:  YES
    
```

- Use [UP] / [DOWN] and [ENTER] to set the values for **Alarm LED**, **Alarm RELAY** and **Alarm CALLBACK** to either **YES** or **NO**.



Setting the **LED** value to **NO** on the **ALARM INFO LEVEL** menu will not disable (i.e., turn off) the level **LED** on the front panel. It will only prevent the **Alarm LED** from flashing given a **LEVEL** condition.

- Press [HOME]. Follow the on-screen prompt (i.e., **SYSTEM CHANGES HAVE BEEN MADE!** menu).

4.3.1.1.3 SETPOINTS: Flow

Like **LEVEL #**, **FLOW** can be configured to activate the **Alarm LED**, activate the **Alarm RELAY** and initiate an **Alarm CALLBACK** event. **FLOW** has the added characteristic that it will disable all relay outputs (i.e., turn them off). The flow input can be disabled by setting S1-2 on the motherboard to OFF (refer to *Section 5 – Diagram 3*, for further information).



To access the **FLOW SETPOINT** menu:

- From the **SETPOINTS** menu, move the prompt to **FLOW**. Press [ENTER]. The **FLOW** menu is displayed.

```

----- SETPOINTS -----
LEVEL 1
LEVEL 2
LEVEL 3
LEVEL 4
FLOW
    
```

```

----- FLOW -----
▶ TYPE   :   FLOW
ACTIVE  :   Open
TIME    =   5.00 Sec

<RELAY LINKS>
<ALARM INFO>
    
```

- On the second line of the screen, the usage **TYPE** field is displayed. At present this field is not changeable.
- Press [SCROLL] to move the prompt to the **ACTIVE** line.

```

----- FLOW -----
TYPE    :   FLOW
▶ ACTIVE :   Open
TIME    =   1.50 Sec

<RELAY LINKS>
<ALARM INFO>
    
```

Press [ENTER] and the switch status is highlighted.

```

----- FLOW -----
TYPE      :      FLOW
ACTIVE    :      Open
TIME      =      1.50 Sec

<RELAY LINKS>
<ALARM INFO>
    
```

Press [UP] / [DOWN] to alternate between **Open** or **Closed**. Press [ENTER] to accept your selection.

4. Press [SCROLL] to move the prompt to the **TIME =** line.

```

----- FLOW -----
TYPE      :      FLOW
ACTIVE    :      Open
▶ TIME    =      1.50 Sec

<RELAY LINKS>
<ALARM INFO>
    
```

Press [ENTER] to enter the **TIME** field. The **TIME** field is used to configure the duration of the de-bounce delay. In other words this field determines how long the contact must remain active before the input is recognized.

```

----- FLOW -----
TYPE      :      FLOW
ACTIVE    :      Closed
TIME      =      01.50 Sec

<RELAY LINKS>
<ALARM INFO>
    
```

The **TIME =** field is a four-digit field. If a single digit setting was used (1.50 seconds in the example above), when the **TIME** field is entered, a 0 is displayed to the left of the 5. The fourth digit will not “hold” an entered value unless the value is less than 1 second.

5. Use [UP] / [DOWN] and [ENTER] to set each digit in the **TIME =** field. Pressing [ENTER] on the fourth digit enters the setting into the system.
6. Press [SCROLL] to move the prompt to the **<RELAY LINKS>** line.

```

----- FLOW -----
TYPE      :      FLOW
ACTIVE    :      Open
TIME      =      1.50 Sec

▶ <RELAY LINKS>
  <ALARM INFO>
    
```

7. Press [ENTER] to open the **<RELAY LINKS>** screen.
The **<RELAY LINKS>** menu allows you to select relays that the **FLOW** input will turn off when it activates.
8. Press [SCROLL] to move the prompt. When the prompt is next to the desired relay (e.g., **RELAY 3**), press [ENTER]. Use [UP] / [DOWN] to select between **NO** (do not turn the relay off) and **YES** (turn the relay off). Press [ENTER] to accept your selection. Press [HOME] to return to the **LEVEL 1** menu.



To return the **LINK** page to the default settings, move the prompt to **RETURN TO DEFAULT** and press [ENTER].

```

----- LINK FLOW -----
▶ RETURN TO DEFAULT
  RELAY 1          YES
  RELAY 2          YES
  RELAY 3          YES
  RELAY 4          YES
  RELAY 5          unused
  RELAY 6          unused
    
```

9. Press [SCROLL] to move the prompt to the **<ALARM INFO>** line.

```

----- FLOW -----
TYPE      :    FLOW
ACTIVE    :    Open
TIME      =    1.50 Sec

<RELAY LINKS>
▶ <ALARM INFO>
    
```

10. Press [ENTER] to open the **<ALARM INFO>** screen.

```

----- ALARM INFO -----
                FLOW

▶ Alarm LED:      YES
  Alarm RELAY:    YES
  Alarm CALLBACK: YES
    
```

11. Use [UP] / [DOWN] and [ENTER] to set the values for **Alarm LED**, **Alarm RELAY** and **Alarm CALLBACK** to either **YES** or **NO**.



Setting the **LED** value to **NO** on the **ALARM INFO LEVEL** menu will not disable (i.e., turn off) the **FLOW LED** on the front panel. It will only prevent the **Alarm LED** from flashing given a **NO FLOW** condition.

12. Press [HOME]. Follow the on-screen prompt (i.e., **SYSTEM CHANGES HAVE BEEN MADE!** menu).

4.4 Timers

Timers are used to dispense chemicals at a user specified rate.

4.4.1 Selectable Timers

The chemical feed timers for this controller are selectable; you can choose one of five modes on which to base the addition of chemical. The selection of a timer mode is made directly from the **TIMERS** menu.

4.4.1.1 Disabled

The **TIMER** type **disabled** is available to allow you to disable the Timer. This assures that the timer will not activate the associated feed relay.



The factory default for Timer Type is disabled.



To set a timer to disabled

1. From the **MAIN MENU**, move the prompt to the **TIMERS** line and press [ENTER]. The **TIMERS** menu is displayed.

```

= = =  MAIN MENU  = = =
      DISPLAY DATA
      SETPOINTS
      ▶ TIMERS
      CONFIGURE
- - - - MODEL 450 - - - -
    
```

```

- - - - - TIMERS - - - - -
      ▶ TIMER      1
      TIMER      2
      TIMER      3
      TIMER      4
      W METER    1
      W METER    2
      W METER    3
    
```

2. Move the prompt to the **TIMER #** (where # is a number between 1 and 4) line. Press [ENTER]. The **TIMER #** menu is displayed. (You will notice that a two character code is displayed after the **TIMER #** (e.g., **R1**). This two character code identifies the relay that is being controlled by the selected timer.)

```

- - - - - TIMER 1  R1
      ▶ TYPE:      disabled
    
```

3. The next line in the display, **TYPE:**, will display the current Timer. Press [ENTER]. Use [UP] / [DOWN] to cycle through the different timer types: **disabled, 28 DAY, Cycle, Pulse, Percent, and Slaved to**. As you display the different values the screen will update with the parameters associated with each timer type.

4. When **disabled** is displayed, press [ENTER] to select it.
5. Press [HOME]. Answer any on-screen prompts if you have made changes.
Repeat steps 1 to 4 to set any additional selectable timers to **disabled**.

4.4.1.2 28 Day Timer

This timer is used to feed chemical on a 28 day-per-month (i.e., 4 week) calendar basis. Each **28 Day Timer** has four individual programs with a wide range of day, week and month setting combinations. A program defines when the timer event is to take place. You specify the start time (**02:00**), the day of the week (**MONDAY**), the week (**ODD**) and the month (**EVERY**). When the conditions of the program are met (for example, today is Monday at 02:00AM, the 3rd week and the 6th month), the feed cycle begins. The feed phase activates the feed relay for a specified amount of time. It also disables the feed of any other timers that are not configured as **28 Day Timers**.



The 28 Day Timer is designed to turn off all other non 28-Day timers during the run/feed portion of the program.

4.4.1.2.1 28 Day Timer: Length of Run/Feed Time

The run time setting represents the length of time that the feed relay will turn on. It is adjustable in one minute increments up to 23 hours and 59 minutes. The **RUN TIME** is common for all four programs.

1. From the **MAIN MENU**, move the prompt to the **TIMERS** line and press [ENTER]. The **TIMERS** menu is displayed.

```

= = = MAIN MENU = = =
  DISPLAY DATA
  SETPOINTS
  ▶ TIMERS
  CONFIGURE
- - - - MODEL 450 - - - -
    
```

```

- - - - - TIMERS - - - - -
  ▶ TIMER      1
  TIMER      2
  TIMER      3
  TIMER      4
  W METER    1
  W METER    2
  W METER    3
    
```

2. Move the prompt to the **TIMER #** (where # is a number between 1 and 4) line. Press [ENTER]. The **TIMER #** menu is displayed. (You will notice that a two character code is displayed after the **TIMER #** (e.g., **R1**). This two character code identifies the relay that is being controlled by the selected timer.)

```

- - - - - TIMER 1 R1
  ▶ TYPE:      28 DAY
  RUN TIME    = 01:30

  <PROGRAMS>
    
```

3. The second line in the display, **TYPE:**, will display the current Timer Type. Press [ENTER]. Use [UP] / [DOWN] to display the different timer types, **disabled, 28 DAY, Cycle, Pulse, Percent, and Slaved to**. As you display the different values the screen will update with the parameters associated with each timer type.
4. Set the **TYPE** to **28 DAY** and press [ENTER].
5. Move the prompt to **RUN TIME**. Press [ENTER]. Use [UP] / [DOWN] / [ENTER] to set the hours and minutes you desire the run time to actuate. Press [ENTER] to accept your changes.

4.4.1.2.2 28 Day Timer: Set Programs

Each **28 day Timer** has four programs, each of which defines conditions for activating the timer. The conditions are: **START TIME, MONTH, WEEK** and **DAY**. In addition to standard settings (i.e., **MON, TUE, WED**) you will find entries such as **EVERY DAY** and **ODD DAY**.



For help with menu locations, please refer to the “Menu Map” supplied with your controller.

1. Move the prompt to the **<PROGRAMS>** line. Press [ENTER]. The **PROG: TIMER #** menu is displayed. The second line of this display indicates the program you are editing (ONE (1) in the example).

```

- - - - TIMER 1 R1
      TYPE:          28 DAY
      RUN TIME   = 01:30

▶ <PROGRAMS>
    
```

```

- - -      PROG:  TIMER  1
▶ PROGRAM:   ONE      (1)

START = 00:00
MONTH:  EVERY MONTH
WEEK:   EVERY WEEK
DAY:    NO DAY
    
```

2. To change to a different program press [ENTER] with the prompt on the **PROGRAM:** line. Use [UP] / [DOWN] to change the program. Press [ENTER] to accept the new program number.

```

- - -      PROG:  TIMER  1
▶ PROGRAM:   ONE      (1)

START = 00:00
MONTH:  EVERY MONTH
WEEK:   EVERY WEEK
DAY:    NO DAY
    
```

3. Move the prompt to **START =**. Press [ENTER]. Use [UP] / [DOWN] / [ENTER] to specify the start time for this program. The value is set in a 24 hour time format. Press [ENTER] to accept the new value.



As you move from one program to another the display will update with the information relevant to that program.

4. Move the prompt to **MONTH:**. Press [ENTER]. Use [UP] / [DOWN] to change the **MONTH** in which the timer should be active. You can select from: **NO MONTH** (disabled), **ODD MONTH**, **EVEN MONTH** and **EVERY MONTH**. Press [ENTER] to accept your change.
5. Move the prompt to **WEEK:**. Press [ENTER]. Use [UP] / [DOWN] to change the **WEEK** number that the timer should be active. You can select from: **NO WEEK** (disabled), **ODD WEEK**, **EVEN WEEK**, **EVERY WEEK**, **1st WEEK**, **2nd WEEK**, **3rd WEEK** or **4th WEEK**. Press [ENTER] to accept your change.
6. Move the prompt to **DAY:**. Press [ENTER]. Use [UP] / [DOWN] to change the **DAY** that the timer should be active. You can select from: **NO DAY** (disabled), **MON**, **TUE**, **WED**, **THU**, **FRI**, **SAT**, **SUN**, and **EVERY**. Press [ENTER] to accept your change.
7. Repeat steps 2 – 6 for the remaining programs.
8. Press [HOME] to return to the **TIMER # R#** screen. Follow any on-screen prompt that may appear.
9. Press [HOME] to return to the **TIMERS** menu. Follow any on-screen prompts that may appear.

Repeat the steps 1 to 9 to configure any additional selectable timers as **28 day Timers**.



Do not configure more than two 28-day timers (e.g., Timer 1 and Timer 2) to run simultaneously or overlap running times. Doing so will cause at least one of the timers to run shorter intervals than expected.

4.4.1.3 Cycle Timer

This timer is used to cycle chemical feed on and off for 24 hours at a time during a 28 day-per-month (i.e., 4 weeks) calendar basis. Each Cycle Timer has four individual programs with a wide range of day, week, and month setting combinations. A program defines when the time event is to take place. You specify the start time (02:00), the day of the week (MONDAY), the week (ODD) and the month (EVERY). When the conditions of the program are met (for example, today is Monday at 02:00AM, the 3rd week and the 6th month), the feed cycle begins. The feed cycle is composed of an on-time and off-time that alternates for 24 hours.

1. From the **MAIN MENU**, move the prompt to the **TIMERS** line and press [ENTER]. The **TIMERS** menu is displayed.

```

===== MAIN MENU =====
  DISPLAY DATA
  SETPOINTS
  ► TIMERS
  CONFIGURE
----- MODEL 450 -----
    
```

```

----- TIMERS -----
  ► TIMER      1
  TIMER      2
  TIMER      3
  TIMER      4
  W METER    1
  W METER    2
  W METER    3
    
```

2. Move the prompt to the **TIMER #** (where # is a number between 1 and 4) line. Press [ENTER]. The **TIMER #** menu is displayed. (You will notice that a two character code is displayed after the **TIMER #** (e.g., **R1**). This two character code identifies the relay that is being controlled by the selected timer.)

CALL 1-800-577-8111 FOR SALES AND SUPPORT

```
- - - - TIMER 1 R1
▶ TYPE:          disabled
```

3. The second line in the display, **TYPE:**, will display the current Timer Type. Press [ENTER]. Use [UP/DOWN] to display the different timer types: **disabled**, **28 DAY**, **CYCLE**, **PULSE**, **PERCENT**, and **Slaved to**. As you display the different values the screen will update with the parameters associated with each timer type.

```
- - - - TIMER 1 R1
▶ TYPE:          CYCLE
  TIME LEFT     00:00:00
  OFF TIME      01:30:00
  ON TIME       30:00
  CYCLES/DAY    12

<PROGRAMS>
```

4. Press [UP] / [DOWN] to set the **TYPE** to **CYCLE** and press [ENTER].
5. Use [SCROLL] to move the prompt to **OFF TIME**. The **OFF TIME** line is where you set the length of time the relay will be off for each cycle.

```
- - - - TIMER 1 R1
  TYPE:          CYCLE
  TIME LEFT     00:00:00
▶ OFF TIME      01:30
  ON TIME       00:30
  CYCLES/DAY    12

<PROGRAMS>
```

Press [ENTER].

```
- - - - TIMER 1 R1
  TYPE:          CYCLE
  TIME LEFT     00:00:00
  OFF TIME      01:30
  ON TIME       00:30
  CYCLES/DAY    12

<PROGRAMS>
```

Use [UP/DOWN] / [ENTER] to set the minutes and seconds you desire for the Off time duration. Press [ENTER] to accept your changes.

- Use [SCROLL] to move the prompt to **ON TIME**. The **On Time** line is where you set the length of time the relay will be turned on for each cycle.

```

- - - - TIMER 1  R1

TYPE:          CYCLE
TIME LEFT     00:00:00
OFF TIME      01:30
▶ ON TIME      00:30
CYCLES/DAY    12

<PROGRAMS>
    
```

Press [ENTER].

```

- - - - TIMER 1  R1

TYPE:          CYCLE
TIME LEFT     00:00:00
OFF TIME      01:30
ON TIME       00:30
CYCLES/DAY    12

<PROGRAMS>
    
```

Use [UP/DOWN] / [ENTER] to set the minutes and seconds you desire the on time to actuate. Press [ENTER] to accept your changes.

- The **CYCLES/DAY** line is where you set the number of ON/OFF cycles you want to occur in a 24 hour period.

```

- - - - TIMER 1  R1

TYPE:          CYCLE
TIME LEFT     00:00:00
OFF TIME      01:30
ON TIME       00:30
▶ CYCLES/DAY  12

<PROGRAMS>
    
```

Use [SCROLL] to move the prompt to **CYCLES/DAY**. Press [ENTER].

Use [UP] / [DOWN] / [ENTER] to set the number of cycles/day. It is adjustable in increments of 1 up to 1440. Press [ENTER] to accept your changes.

4.4.1.3.1 Cycle Timer: Set Programs

Each **Cycle Timer** has four programs, each of which defines conditions for activating the timer. The conditions are: **START TIME, MONTH, WEEK** and **DAY**. In addition to standard settings (i.e., **MON, TUE, WED**) you will find entries such as **EVERY DAY** and **ODD DAY**.



For help with menu locations, please refer to the “Menu Map” supplied with your controller.

1. Move the prompt to the **<PROGRAMS>** line. Press [ENTER]. The **PROG: TIMER #** menu is displayed. The second line of this display indicates the program you are editing (ONE (1) in the example).

```

- - - - TIMER 1 R1

TYPE:          CYCLE
TIME LEFT     00:00:00
OFF TIME      01:30:00
ON TIME       30:00
CYCLES/DAY    12

▶ <PROGRAMS>
    
```

```

- - -          PROG:  TIMER  1
▶ PROGRAM:     ONE      (1)

START = 00:00
MONTH:  EVERY MONTH
WEEK:   EVERY WEEK
DAY:    NO DAY
    
```

2. To change to a different program press [ENTER] with the prompt on the **PROGRAM:** line. Use [UP] / [DOWN] to change the program. Press [ENTER] to accept the new program number.

```

- - -          PROG:  TIMER  1
▶ PROGRAM:     ONE      (1)

START = 00:00
MONTH:  EVERY MONTH
WEEK:   EVERY WEEK
DAY:    NO DAY
    
```

3. Move the prompt to **START =**. Press [ENTER]. Use [UP] / [DOWN] / [ENTER] to specify the start time for this program. The value is set in a 24 hour time format. Press [ENTER] to accept the new value.



As you move from one program to another the display will update with the information relevant to that program.

4. Move the prompt to **MONTH:** Press [ENTER]. Use [UP] / [DOWN] to change the **MONTH** in which the timer should be active. You can select from: **NO MONTH** (disabled), **ODD MONTH**, **EVEN MONTH** and **EVERY MONTH**. Press [ENTER] to accept your change.
5. Move the prompt to **WEEK:** Press [ENTER]. Use [UP] / [DOWN] to change the **WEEK** number that the timer should be active. You can select from: **NO WEEK** (disabled), **ODD WEEK**, **EVEN WEEK**, **EVERY WEEK**, **1st WEEK**, **2nd WEEK**, **3rd WEEK** or **4th WEEK**. Press [ENTER] to accept your change.
6. Move the prompt to **DAY:** Press [ENTER]. Use [UP] / [DOWN] to change the **DAY** that the timer should be active. You can select from: **NO DAY** (disabled), **MON**, **TUE**, **WED**, **THU**, **FRI**, **SAT**, **SUN**, and **EVERY**. Press [ENTER] to accept your change.
7. Repeat steps 2 – 6 for the remaining programs.
8. Press [HOME] to return to the **TIMER # R#** menu. Follow any on-screen prompt that may appear.
9. Press [HOME] to return to the **TIMERS** menu. Follow any on-screen prompts that may appear.

Repeat the steps 1 to 9 to configure any additional selectable timers as **Cycle Timers**.

4.4.1.4 Pulse Timer

This timer is commonly referred to as a water meter or reset timer. It monitors pulses from a water meter. When the counts reach a specified maximum, it feeds for an adjustable time interval. At the same time it resets the count and recycles. The **RUN TIME** can be set to a maximum of 59 minutes and 59 seconds. The **PULSE SET** can be set to a maximum of 32,000. The water meter input can also be specified. This allows you to run multiple **PULSE** timers from a single water meter input.



Water meter inputs include a six second de-bounce delay. This means the switch must be closed for six seconds (minimum) then open for six seconds (minimum) before the count will be incremented.



To configure a timer as a **PULSE TIMER**:

1. From the **MAIN MENU**, move the prompt to the **TIMERS** line and press [ENTER]. The **TIMERS** menu is displayed.

```

= = = MAIN MENU = = =
  DISPLAY DATA
  SETPOINTS
  ▶ TIMERS
  CONFIGURE
- - - - MODEL 450 - - - -
    
```

```

- - - - - TIMERS - - - - -
  ▶ TIMER      1
  TIMER      2
  TIMER      3
  TIMER      4
  W METER    1
  W METER    2
  W METER    3
    
```

2. Move the prompt to the **TIMER #** (where # is a number between 1 and 4) line. Press [ENTER]. The **TIMER #** menu is displayed. (You will notice that a two character code is displayed after the **TIMER #** (e.g., **R1**). This two character code identifies the relay that is being controlled by the selected timer.)
3. The second line in the display, **TYPE:**, will display the current Timer Type. Press [ENTER]. Use [UP] / [DOWN] to display the different timer Types: **disabled, 28 Day, CYCLE, PULSE, PERCENT,** and **Slaved to**. As you display the different values the screen will update with the parameters associated with each timer type.
4. Set the **TYPE** to **PULSE** and press [ENTER].

```

- - - - - TIMER 1 R1
  ▶ TYPE:          Pulse
  RUN TIME =      00:30
  TIME LEFT  00:00
  PULSE SET =      10
  PULSE CNT =      0
  WATER METER: ONE
    
```

```

----- TIMER 1 R1 -----
  ▶ TYPE:          Pulse
  RUN TIME =      00:00 M:S
  TIME LEFT  00:00
  GALLONS -
  SET =              10
  COUNT           0
  WATER METER:     ONE
    
```

- The third line, **RUN TIME**, is where you set the number of minutes and seconds you want the feed to activate when the **PULSE SET** is achieved. Use [UP] / [DOWN] / [ENTER] to set

```

- - - - - TIMER 1  R1
  ▶ TYPE:          Pulse
  RUN TIME =      00:30
  TIME LEFT      00:00
  PULSE SET =     10
  PULSE CNT =     0
  WATER METER:   ONE
    
```

```

----- TIMER 1  R1 -----
  ▶ TYPE:          Pulse
  RUN TIME =      00:00 M:S
  TIME LEFT      00:00
  GALLONS -
  SET =           10
  COUNT          0
  WATER METER:   ONE
    
```

the Minutes and Seconds. Press [ENTER] to accept the value you have set.

- The fourth line in this display, **TIME LEFT**, indicates the amount of time left until the timer reaches it's limit (i.e., 00:00) and shuts off the feed. You cannot change this field. This value will always be between the specified **RUN TIME** and 00:00. It will display 00:00 until the feed is activated, at which time it will begin to count down from the **RUN TIME**.
- Move the prompt to the **PULSE SET =** line. Press [ENTER]. Use [UP] / [DOWN] / [ENTER] to set the number of pulses that should be counted before the feed is activated. The value can be set between 1 and 32,000. Press [ENTER] to accept your setting.

```

- - - - - TIMER 1  R1
  ▶ TYPE:          Pulse
  RUN TIME =      00:30
  TIME LEFT      00:00
  PULSE SET =     10
  PULSE CNT =     0
  WATER METER:   ONE
    
```

```

----- TIMER 1  R1 -----
  ▶ TYPE:          Pulse
  RUN TIME =      00:00 M:S
  TIME LEFT      00:00
  GALLONS -
  SET =           10
  COUNT          0
  WATER METER:   ONE
    
```

- The sixth line in this menu, **PULSE CNT**, displays the current pulse count. You cannot edit this value. When the **PULSE CNT** reaches the **PULSE SET** the feed will activate for the **RUN TIME** interval. The **PULSE CNT** will then reset to zero.
- Move the prompt to the **WATER METER:** line. Press [ENTER]. Use [UP] / [DOWN] to select a water meter input to operate from. You can select **ONE** or **TWO** to operate from the Water Meter #1 or Water Meter #2 respectively. Press [ENTER] after making your selection.
- Press [HOME] to return to the **TIMERS** menu. Follow any on screen prompts if you made changes.

Repeat steps 1 to 8 to configure any additional **Selectable Timers** as **Pulse Timers**.

4.4.1.5 Percent Timer

Also referred to as a **CYCLE** timer. The timer runs continuously on an adjustable percentage of the time cycle. The percentage is adjustable from 0 to 99% in 1% increments. The cycle time is adjustable from 1 to 255 minutes.

- From the **MAIN MENU**, press [SCROLL] to move the prompt to the **TIMERS** line. Press [ENTER]. The **TIMERS** menu is displayed.

2. Move the prompt to the **TIMER #** (where # is a number between 1 and 5) line. Press [ENTER]. The **TIMER #** menu is displayed. (You will notice that a two character code is displayed after the **TIMER #** (e.g., **R1**). This two character code identifies the relay that is being controlled by the selected timer.)
3. The second line in the display, **TYPE:**, will display the current timer type. If necessary, move the prompt to the **TYPE** line and press [ENTER]. Use [UP] / [DOWN] / [ENTER] to display the different timer types: **disabled, 28 Day, CYCLE, PULSE, PERCENT**, and **Slave to**. As you display the different values the screen will update with the parameters associated with each timer type.

```

- - - - - TIMER 1  R1
▶ TYPE:          PERCENT
RUN TIME        00:05:00
TIME LEFT       00:00:00
PERCENT:        50 %
% MINUTES =     10
    
```

4. Set the **TYPE** to **PERCENT** and press [ENTER].
5. The third line, **RUN TIME**, cannot be changed. This line indicates the on time in Hours, Minutes and Seconds. Like wise, the fourth line, **TIME LEFT**, cannot be changed. This line indicates the time remaining for the ON or OFF period of the cycle.
6. Move the prompt to the **PERCENT:** line. Press [ENTER]. Use the [UP] / [DOWN] / [ENTER] to select the percentage value. This is the percentage of ON time. The value can be set from 0 to 99% in 1% increments. Press [ENTER] to accept your setting.
7. Move the prompt to the **% MINUTES** line. Press [ENTER]. Use [UP] / [DOWN] / [ENTER] to set the number of minutes in the percentage cycle. For example, if you set the **PERCENT** to 75% and the **% MINUTES** to 4, then the relay will turn on for 3 minutes ($4 \times .75 = 3$) and off for 1 minute ($4 \times .25 = 1$).
8. Press [HOME] to return to the **TIMERS** menu. Follow any on screen prompts if you made changes.
Repeat steps 1 to 8 to configure any additional **Selectable Timers** as **Percent Timers**.

4.4.1.6 Slaved to Timer

This timer turns on its output when one or more selected relays activate. The relays can be “slaved” in any combination. For example, if Timer #1 (Relay #3) is set to PULSE and you would like it to activate two relays, you can set Timer #2 (Relay #4) to “**Slave to**” with the **Slave to** relay set to Relay #3. Thus when Relay #3 activates so will Relay #4.



To configure your **Slave to** option:

1. From the **MAIN MENU**, move the prompt to the **TIMERS** line and press [ENTER]. The **TIMERS** menu is displayed.

```

= = = MAIN MENU = = =
  DISPLAY DATA
  SETPOINTS
  ▶ TIMERS
  CONFIGURE
- - - - MODEL 450 - - - -
    
```

```

- - - - - TIMERS - - - - -
  ▶ TIMER      1
  TIMER      2
  TIMER      3
  TIMER      4
  W METER    1
  W METER    2
  W METER    3
    
```

2. Move the prompt to the **TIMER #** (where # is a number between 1 and 5) line. Press [ENTER]. The **TIMER #** menu is displayed. (You will notice that a two character code is displayed after the **TIMER #** (e.g., **R1**). This two character code identifies the relay that is being controlled by the selected timer.)

The prompt is displayed on the **TYPE** line.

```

- - - - - TIMER 1 R1
  ▶ TYPE          disabled
    
```

3. Press [ENTER]. Use [UP] / [DOWN] / [ENTER] to display the different timer types: **disabled**, **28 DAY**, **CYCLE**, **PULSE**, **PERCENT**, and **Slaved to**. As you display the different values, the screen will update with the parameters associated with each timer type.

```

- - - - - TIMER 1 R1
  TYPE          disabled
    
```

- Set the type to **Slaved to** and press [ENTER].

```

- - - - - TIMER 1  R1
TYPE           Slaved to
RELAY 1:      NO
RELAY 2:      NO
RELAY 3:      NO
RELAY 4:      NO
RELAY 5:      unused
RELAY 6:      unused
    
```

- Lines 3 through 8 show the '**Slaved to**' status of all 6 relays. If the value is set to NO the relay will be ignored. If the '**Slaved to**' value is set to YES, then the timer relay will turn on when one or more of the selected relay(s) turn(s) on.
- Press [SCROLL] to move the prompt to the relay you desire to change (in the example **RELAY 2**).

```

- - - - - TIMER 1  R1
TYPE           Slaved to
RELAY 1:      NO
▶ RELAY 2:      NO
RELAY 3:      NO
RELAY 4:      NO
RELAY 5:      unused
RELAY 6:      unused
    
```

- Press [UP] or [DOWN] to change the status from NO to YES. When the status is set to YES the Timer relay will activate with that relay.



The Slave to timer relay will activate when any one (not all) of the relays whose status is set to YES activate.

If you are only going to slave a single relay to this timer press [HOME] and follow the on screen prompts to save your change, or if you desire to slave additional relays to this timer:

- Follow steps 5, 6, 7, and 8 to slave additional relays to this timer.

4.4.2 Water Meter Inputs

The Water meter input menu allows you to view accumulated water meter counts and the amount of water that has passed with those counts. You can use this information to track your water usage. In this menu, you enter the flow per water meter pulse (e.g., gallons per pulse) in the **MULTIPLIER =** field. The menu also allows you to reset the count. The last reset date is displayed at the bottom of the menu.



To configure your water meter inputs:

1. From the **MAIN MENU**, move the prompt to the **TIMERS** line and press [ENTER]. The **TIMERS** menu is displayed.

```

===== MAIN MENU =====
DISPLAY DATA
CALIBRATION
SETPOINTS
▶ TIMERS
DATA COLLECT
CONFIGURE
----- SER 450 -----
    
```

```

----- TIMERS -----
▶ TIMER 1
TIMER 2
TIMER 3
TIMER 4
W METER 1
W METER 2
W METER 3
    
```

2. Move the prompt to the **W METER #** (where # is either 1 or 2) line. Press [ENTER]. The **W METER 1** menu is displayed. (**W Meter 1** is being used for our example.) The prompt is displayed on the **<NEXT SCREEN>** line.

```

----- W METER 1 -----
▶ <NEXT SCREEN>
CURRENT READING
                                0
PULSE CNT                       0
TOTALIZER GALLONS
                                0
RESET                            01-Jan-2000
    
```

3. The third line in the display, **PULSE CNT**, displays the current pulse count for the water meter input. This value can be re-set through the **RESET COUNT** line described in a later step.
4. The line below the label **TOTALIZER** displays the totalized flow. The controller arrives at this number by multiplying the **PULSE CNT** by the **MULTIPLIER**. For example, 21 counts times 100 gallons per count equals 2100 gallons.



The water meter PULSE CNT field can display 999999 pulses. It will roll to 0 with the next pulse. The totalizer can display a maximum of 999999000.

CALL 1-800-577-8111 FOR SALES AND SUPPORT

5. Press [SCROLL] to position the prompt next to the **TYPE:** line

```
----- W METER 1 -----  
<NEXT SCREEN>  
▶ TYPE : HALL EFFECT  
FACTOR = 50.000  
  
UNITS: GALLONS  
BASE = 0
```

6. Press [ENTER]. Use [UP] / [DOWN] to select between **DRY CONTACT** or **HALL EFFECT**. Press [ENTER].

7. Press [UP] / [DOWN] to select “NO” to “YES”. Press [ENTER] to accept selection.

```
ARE YOU SURE ???  
↑↓ NO ↑↓
```

8. If **DRY CONTACT** is selected

```
----- W METER 1 -----  
<NEXT SCREEN>  
▶ TYPE : DRY CONTACT  
ACTIVE: Closed  
TIME = 20.00 Sec  
MULTIPLIER = 100  
UNITS: GALLONS  
BASE = 0
```

9. Press [SCROLL] to position the prompt next to the **ACTIVE:** line. Press [ENTER]. Use [UP] / [DOWN] to select between **Open** or **Closed**. If **Closed** is selected then the water meter will count when the input is closed.

```
----- W METER 1 -----  
<NEXT SCREEN>  
▶ ACTIVE: Closed  
TIME = 20.00 Sec  
MULTIPLIER = 100  
UNITS: GALLONS  
BASE = 0
```

Press [ENTER] to set the value.

CALL 1-800-577-8111 FOR SALES AND SUPPORT

10. Press [SCROLL] to position the prompt on **TIME:**. The **TIME:** entry is used to set the amount of time the water meter contact must be closed (or open) before it is recognized. You can set a value between 20.00 and 0.02 seconds.

```
----- W METER 1 -----  
<NEXT SCREEN>  
TYPE   :   DRY CONTACT  
ACTIVE:   Closed  
▶ TIME  =   20.00 Sec  
MULTIPLIER =    100  
UNITS:   GALLONS  
BASE =                                0
```

Press [UP] / [DOWN] to set each digit, pressing [ENTER] to move to the second and subsequent digits. When the time value has been set, press [ENTER] and the prompt will re-appear next to **TIME**.

11. Press [SCROLL] to move the prompt to the **MULTIPLIER=** line.

```
----- W METER 1 -----  
<NEXT SCREEN>  
TYPE   :   DRY CONTACT  
ACTIVE:   Closed  
TIME   =   20.00 Sec  
▶ MULTIPLIER =    100  
UNITS:   GALLONS  
BASE =                                0
```

12. Press [ENTER]. Use [UP] / [DOWN] to set the ratio of volume units per pulse. For example, if your water meter registers 1 pulse for 100 gallons of water measured, you would enter 100 here. Likewise, if your water meter registers 1 pulse for 12 liters you would enter 12 here. The value can be set between 1 and 1000. Press [ENTER] to accept your entry.

13. Press [SCROLL] to move the prompt to the **UNITS:** line.

```
----- W METER 1 -----  
<NEXT SCREEN>  
TYPE   :   DRY CONTACT  
ACTIVE:   Closed  
TIME   =   20.00 Sec  
MULTIPLIER =    100  
▶ UNITS:   GALLONS  
BASE =                                0
```

14. Press [ENTER]. Use [UP] / [DOWN] to select between **GALLONS** and **LITERS**. Press [ENTER].

15. Press [SCROLL] to move the prompt to the **BASE =** line.

```

----- W METER 1 -----
<NEXT SCREEN>
TYPE   :   DRY CONTACT
ACTIVE:   Closed
TIME   =  20.00 Sec
MULTIPLIER =   100
UNITS:   GALLONS
▶ BASE =                               0
    
```

Press [ENTER]. Use [UP] / [DOWN] to set **BASE**. Press [ENTER]. The value can be set between 1 and 90,000,000. Press [HOME] . To accept your changes, press [ENTER]. To reject your changes press [HOME].

```

---- SYSTEM CHANGES ----
      HAVE BEEN MADE !

      ?? SAVE CHANGES ??

Press ENTER to SAVE
Press HOME to ABORT
    
```

16. If **HALL EFFECT** is selected

```

----- W METER 1 -----
<NEXT SCREEN>
▶ TYPE   :   HALL EFFECT
  FACTOR =   50.000

UNITS:   GALLONS
BASE =                               0
    
```

17. Press [SCROLL] to position the prompt next to the **FACTOR =** line. Press [ENTER]. Use [UP] / [DOWN] to set the “K” FACTOR. Press [ENTER] to set the value. The value can be set between .001 and 90,000.000.

```

----- W METER 1 -----
<NEXT SCREEN>
▶ TYPE   :   HALL EFFECT
  FACTOR =   50.000

UNITS:   GALLONS
BASE =                               0
    
```

Press [ENTER] until the prompt is positioned next to **FACTOR =**

18. Press [SCROLL] to move the prompt to the **UNITS:** line.

```

----- W METER 1 -----
<NEXT SCREEN>
TYPE   :   HALL EFFECT
FACTOR =       50.000

▶ UNITS:   GALLONS
  BASE =           0
    
```

19. Press [ENTER]. Use [UP] / [DOWN] to select between **GALLONS** and **LITERS**. Press [ENTER].

20. Press [SCROLL] to move the prompt to the **BASE =** line.

```

----- W METER 1 -----
<NEXT SCREEN>
TYPE   :   HALL EFFECT
FACTOR =       50.000

  UNITS:   GALLONS
▶ BASE =           0
    
```

Press [ENTER]. Use [UP] / [DOWN] to set **BASE**. Press [ENTER]. The value can be set between 1 and 90,000,000. Press [HOME] . To accept your changes, press [ENTER]. To abort your changes press [HOME]. If the changes have been aborted the water meter menu will appear again. If the changes were saved the timers menu will appear.

```

----- SYSTEM CHANGES -----
      HAVE BEEN MADE !

      ?? SAVE CHANGES ??

  Press ENTER to SAVE
  Press HOME to ABORT
    
```

21. To reset the Pulse Count the water meter menu must appear on the screen.

22. Press [SCROLL] to move the prompt to the **RESET** line.

```

----- W METER 1 -----

<NEXT SCREEN>
CURRENT READING
                                0
PULSE CNT                       0
TOTALIZER  GALLONS
                                0
▶ RESET                          01-Jan-2000
    
```

Press [ENTER] and the **PULSE COUNT** line will indicate **0**. The **Reset on** line will indicate the date the reset occurred.

23. Press [HOME]. Follow the on-screen prompt (i.e., **SYSTEM CHANGES HAVE BEEN MADE!** menu).

```
----- SYSTEM CHANGES -----  
          HAVE BEEN MADE !  
  
          ?? SAVE CHANGES ??  
  
Press ENTER to SAVE  
Press HOME to ABORT
```

4.5 Display Data

4.5.1 Display Data: Auto Scroll Mode

Whenever the system is idle (no one presses any keys on the keyboard) for approximately 5 minutes, the display will enter an AUTO SCROLL mode. The screens in **DISPLAY DATA** will automatically cycle every 5 seconds.

```
= = = MAIN MENU = = =  
  
▶ DISPLAY DATA  
  SETPOINTS  
  TIMERS  
  CONFIGURE  
  
- - - - MODEL 450 - - - -
```

The **DISPLAY DATA** screens are as follows:

4.5.1.1 Date/Time/Version

Here you will find information relative to the data/time of the controller as well as version information.

```
999 DATE/TIME/VER 999  
  
DATE      01-Jan-2000  
TIME      15:00:46  
WEEK      1st,   FRI  
VERSION   MODEL4XX.XXX  
CHECKSUM          1531  
-   ENTER to Unlock   -
```

4.5.1.2 Relay Time

This screen displays the accumulated relay on-times. The time is formatted as: DD:HH:MM:SS. Where D = Day, H = Hour, M = Minute and S = Seconds.

```
9999 RELAY TIME 9999
R1 - 2 22:59:00
  TIMER 1
R2 - 0 00:42:06
  TIMER 2
R3 - 0 00:30:00
  TIMER 3
- ENTER to Unlock -
```

```
9999 RELAY TIME 9999
R4 - 0 00:00:00
  TIMER 4
R5 - 0 00:00:00
  unused
R6 - 0 00:00:00
  unused
- ENTER to Unlock -
```

4.5.1.3 Alarms

Indicates current alarms.

```
99999 ALARMS 99999
LEVEL 1 ALARM

- ENTER to Unlock -
```

5. Diagrams: Installation, Component, And Electrical

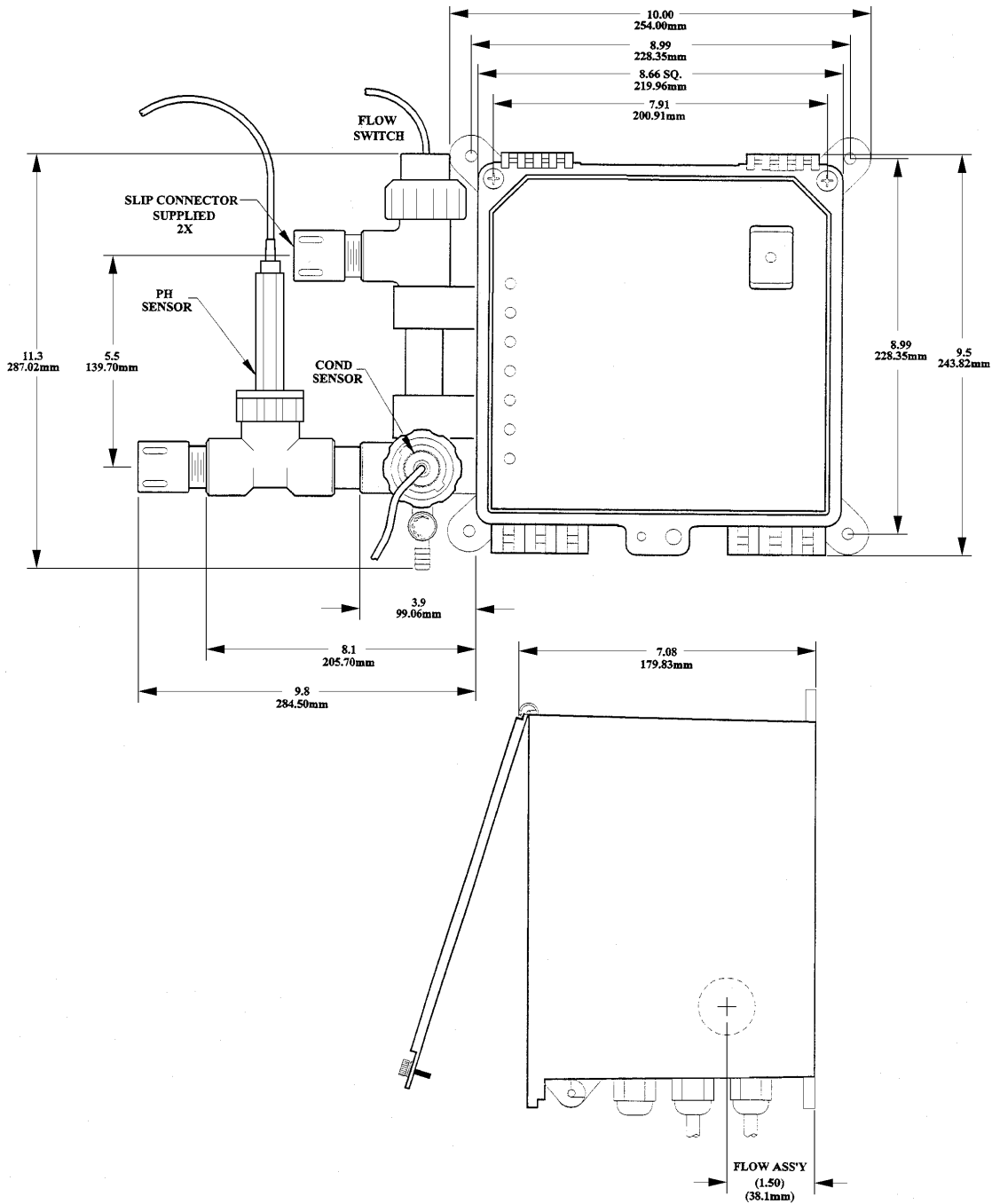
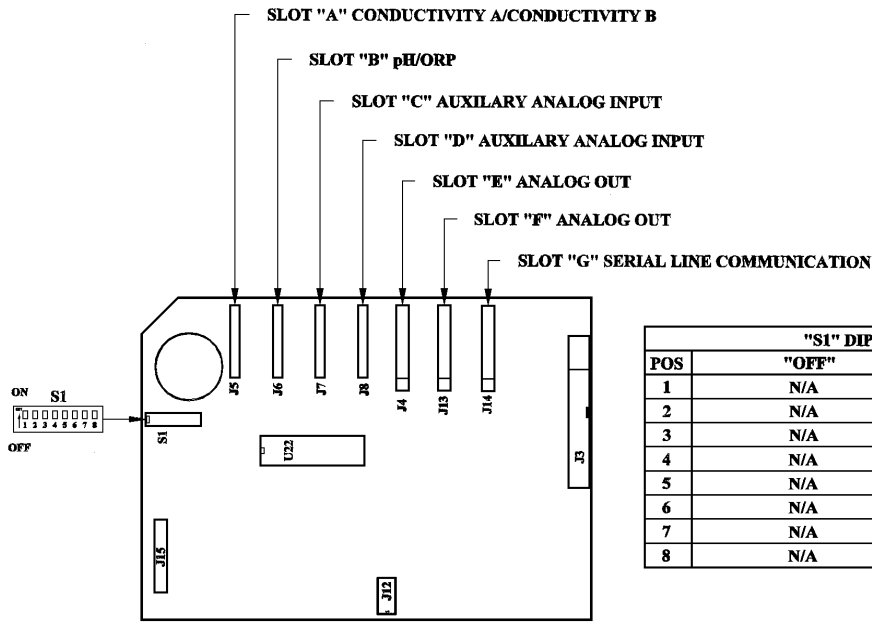

DIAGRAM 1 – ENCLOSURE DIMENSIONAL DATA

MOTHER BOARD

ANALOG SIGNAL DAUGHTER BOARD SLOT LOCATIONS, IF CONTROLLER IS SO EQUIPPED



J12

- 1 +5VDC
- 2 GROUND
- 3 +12VDC
- 4 GROUND
- 5 -12VDC
- 6 GROUND

"S1" DIP SWITCH SETTINGS		
POS	"OFF"	"ON"
1	N/A	N/A
2	N/A	FLOW SWITCH #1 ENABLE
3	N/A	N/A
4	N/A	N/A
5	N/A	N/A
6	N/A	N/A
7	N/A	DIAGNOSTICS
8	N/A	FACTORY RE-INIT

DAUGHTER BOARD INSTALLATION/CONNECTION MAP

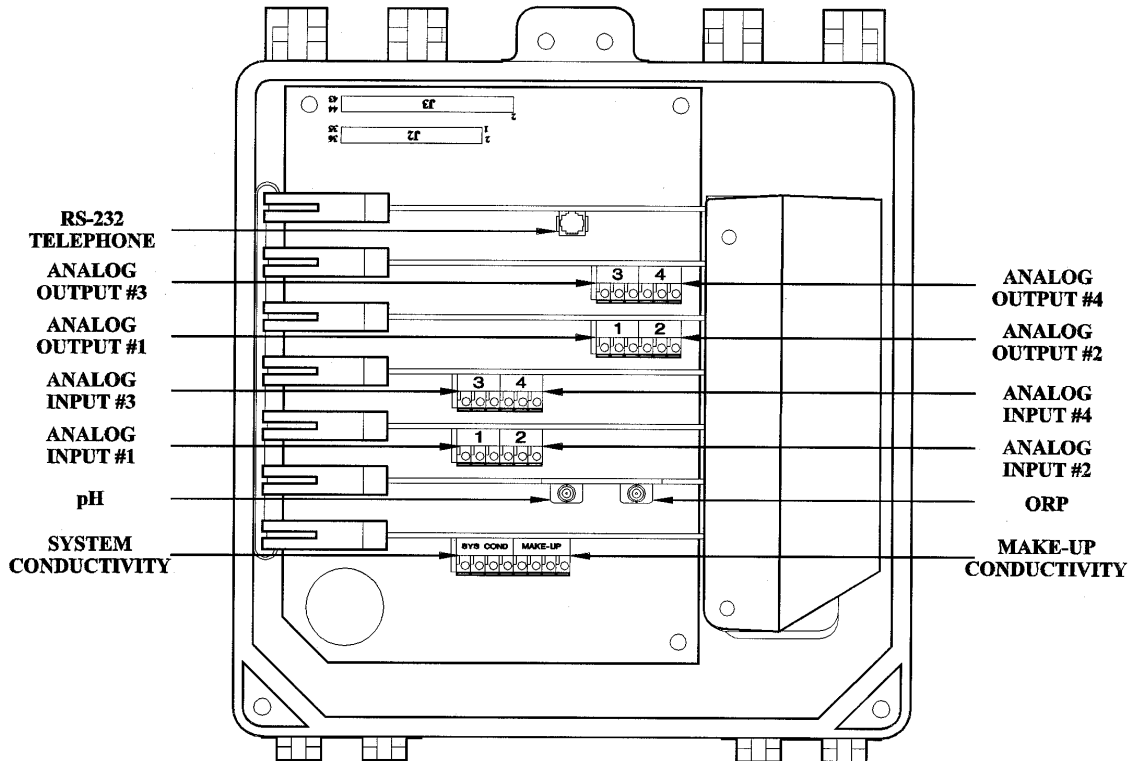

DIAGRAM 3 MOTHER BOARD / INSTALLATION CONNECTION MAP

Field installation of daughter board/cable assembly – Serial line communication with or without modem.

1. Disconnect power to unit at main. Open enclosure and remove power supply cover.
2. Pass Cable through tapped hole "P" in enclosure, if provided. If not, punch out an unused knockout in bottom of enclosure and use a lock-nut to secure the cable (2). See "Optional Route" in illustration below.
3. Attach Cable to daughter card jack labeled "J2". Insert card in slot closest to hinge. When inserting card, check the alignment of the pins with the connector.
4. Re-install power supply cover.
5. Check all internal connections and close unit.
6. Insert free plug on cable 2 into either adapter 4 (direct com) or adapter 5 (phone line).
7. Attach adapter to appropriate interface: 1) The serial port on your PC, or 2) A telephone line jack.
8. Re-connect power at the main.

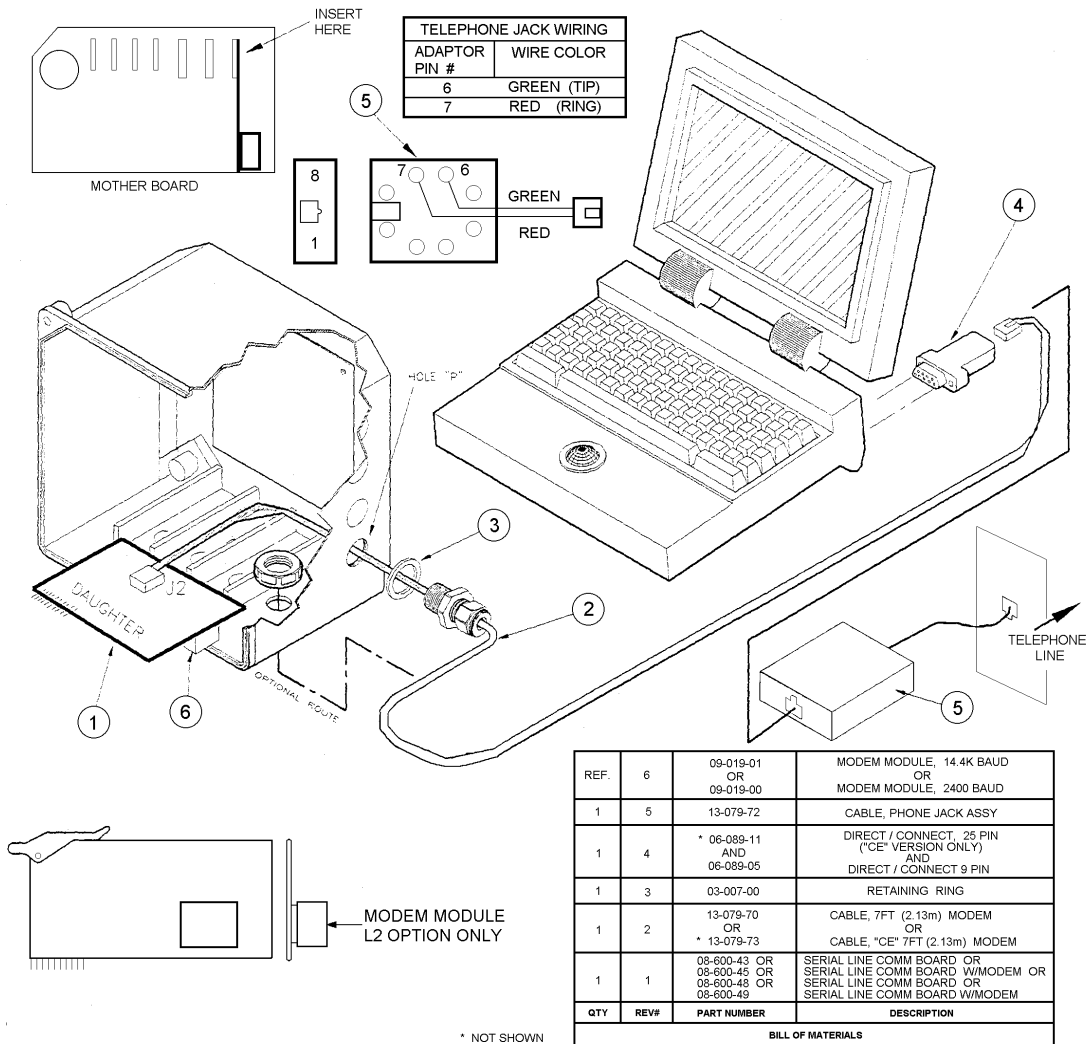

DIAGRAM 4 – SERIAL / INTERNAL MODEM COMMUNICATIONS OPTION, FIELD INSTALLATION

SERIAL LINE COMMUNICATION DAUGHTER BOARD

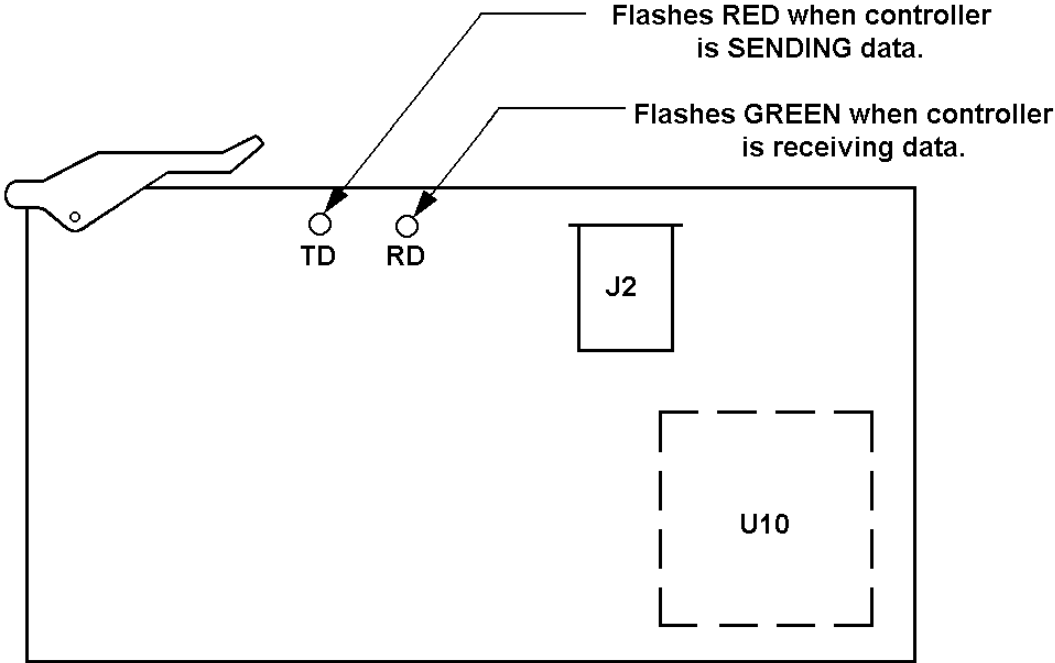
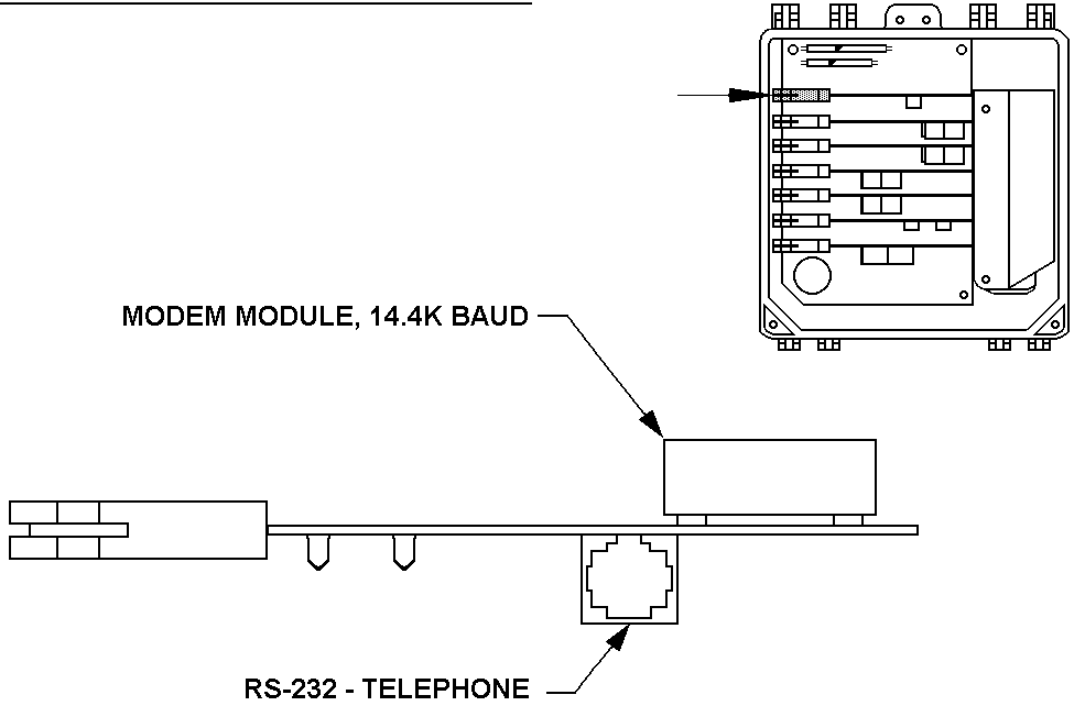
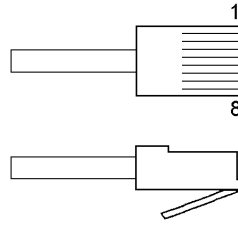

DIAGRAM 5 – SERIAL / INTERNAL MODEM COMMUNICATIONS DAUGHTER BOARD

CABLE * PIN-OUT

* CABLE IS WIRED STRAIGHT THROUGH, PIN #1 TO PIN #1, ETC.



RJ-45	
POS.	POS.
1	ISO GROUND
2	RS-232 IN
3	RS-232 OUT
4	ISO GROUND
5	CTS
6	RING
7	TIP
8	RTS

RJ-45	
POS.	POS.
1	NC
2	NC
3	NC
4	NC
5	NC
6	RING
7	TIP
8	NC

TELEPHONE LINE ADAPTER

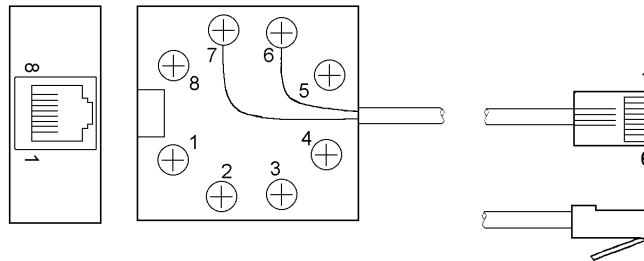

RJ-11	
POS.	POS.
1	NC
2	NC
3	RING
4	TIP
5	NC
6	NC

RJ-45	
POS.	POS.
1	NC
2	RS-232 IN
3	RS-232 OUT
4	ISO GROUND
5	CTS*
6	NC
7	NC
8	RTS*

SERIAL PORT ADAPTER

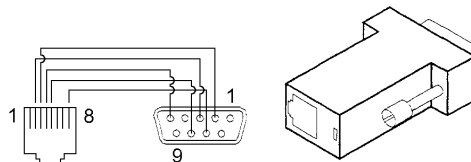

DB-9	
POS.	POS.
1	NC
2	RS-232 OUT
3	RS-232 IN
4	NC
5	ISO GROUND
6	NC
7	RTS
8	CTS
9	NC

* CTS SHORTED TO RTS ON DAUGHTER CARD.

Note:
DO NOT plug the telephone line adapter into the serial line adapter.

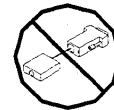

WARNING

DO NOT plug the oversized modular telephone plug into a digital phone system or Local Area Network! You may damage the unit and void the warranty.

DIAGRAM 6 – SERIAL / INTERNAL MODEM ADAPTER PIN-OUTS

"STANDARD" POWER SUPPLY BOARD

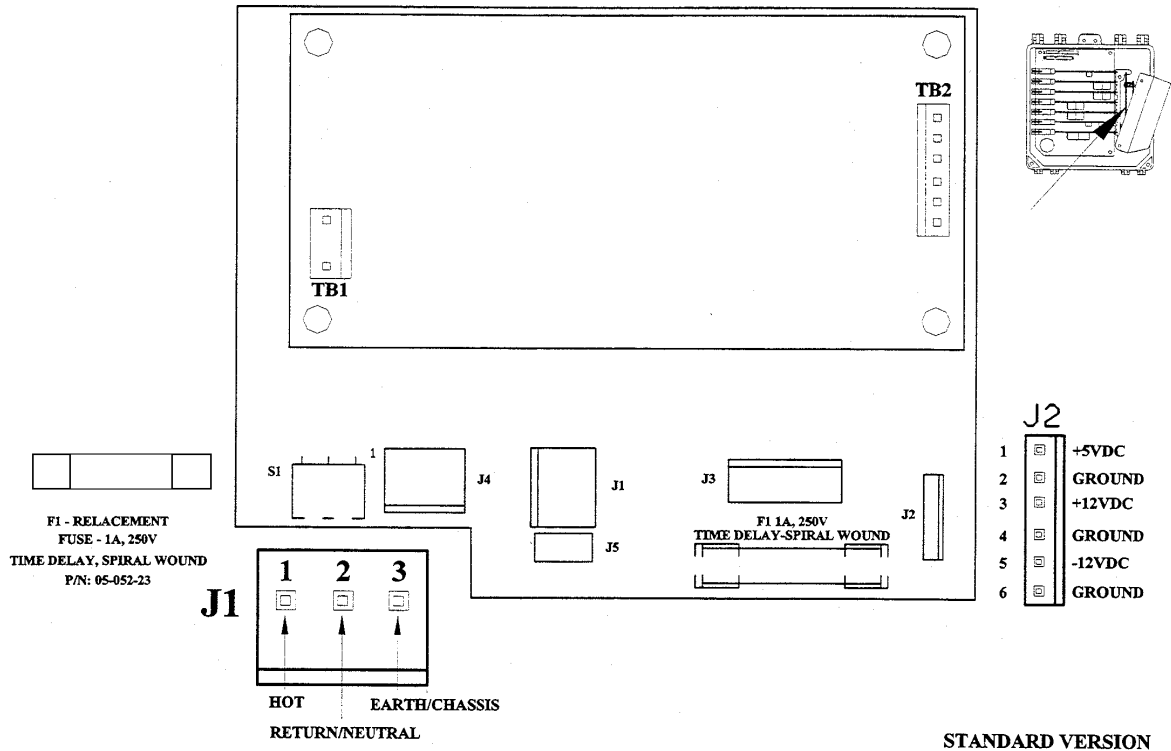

"CE" POWER SUPPLY BOARD

"CE" VERSION

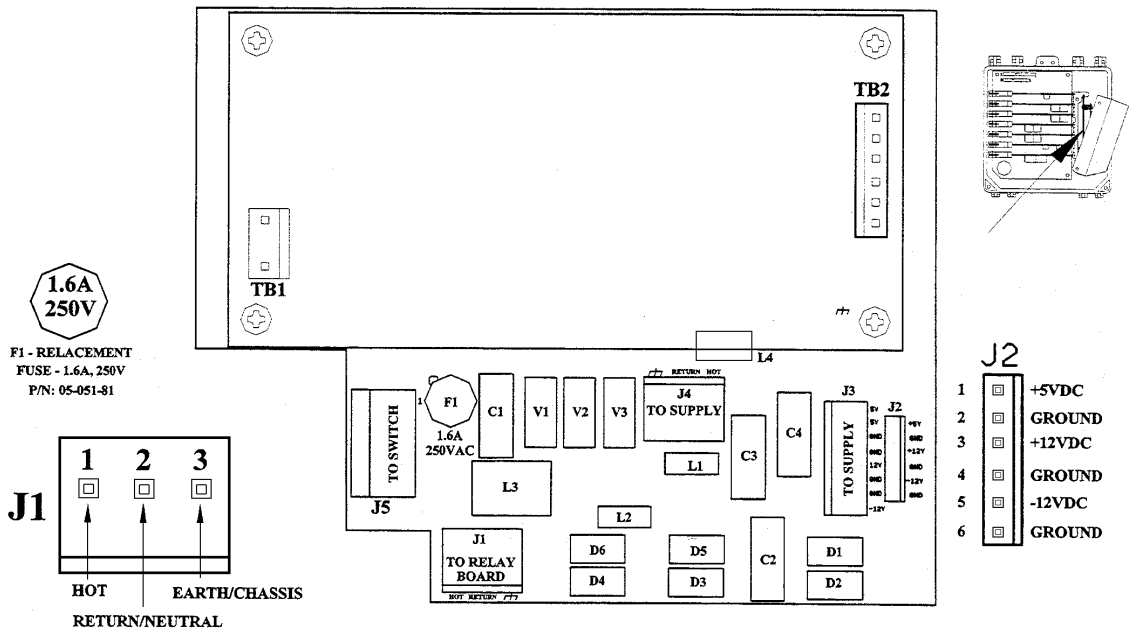

NOTES:

1. ONLY (4) LEVEL ALARMS ARE INDICATED ON THE PANEL. IT IS RECOMMENDED THAT THE FIRST WAND BE CONNECTED TO #1, THE SECOND CONNECTED TO #2 AND SO ON.
2. THE ALARM IS ACTIVATED WHEN THE SWITCH IS CLOSED.
3. THE FUNCTION OF THE WAND MAY BE CHANGED BY FLIPPING THE FLOAT. THE WAND IS SHIPPED FROM THE FACTORY SUCH THAT THE SWITCH IS CLOSED WHEN THE TANK LEVEL IS LOW.

16-171-81-1 46" (1.17m)
 16-171-81-2 26" (.66m)
 16-171-81-4 60" (1.52m)
 ABOVE INCLUDE A 10' (3.66m)
 EXTENSION CABLE
 16-171-81-3

SEE NOTE #3

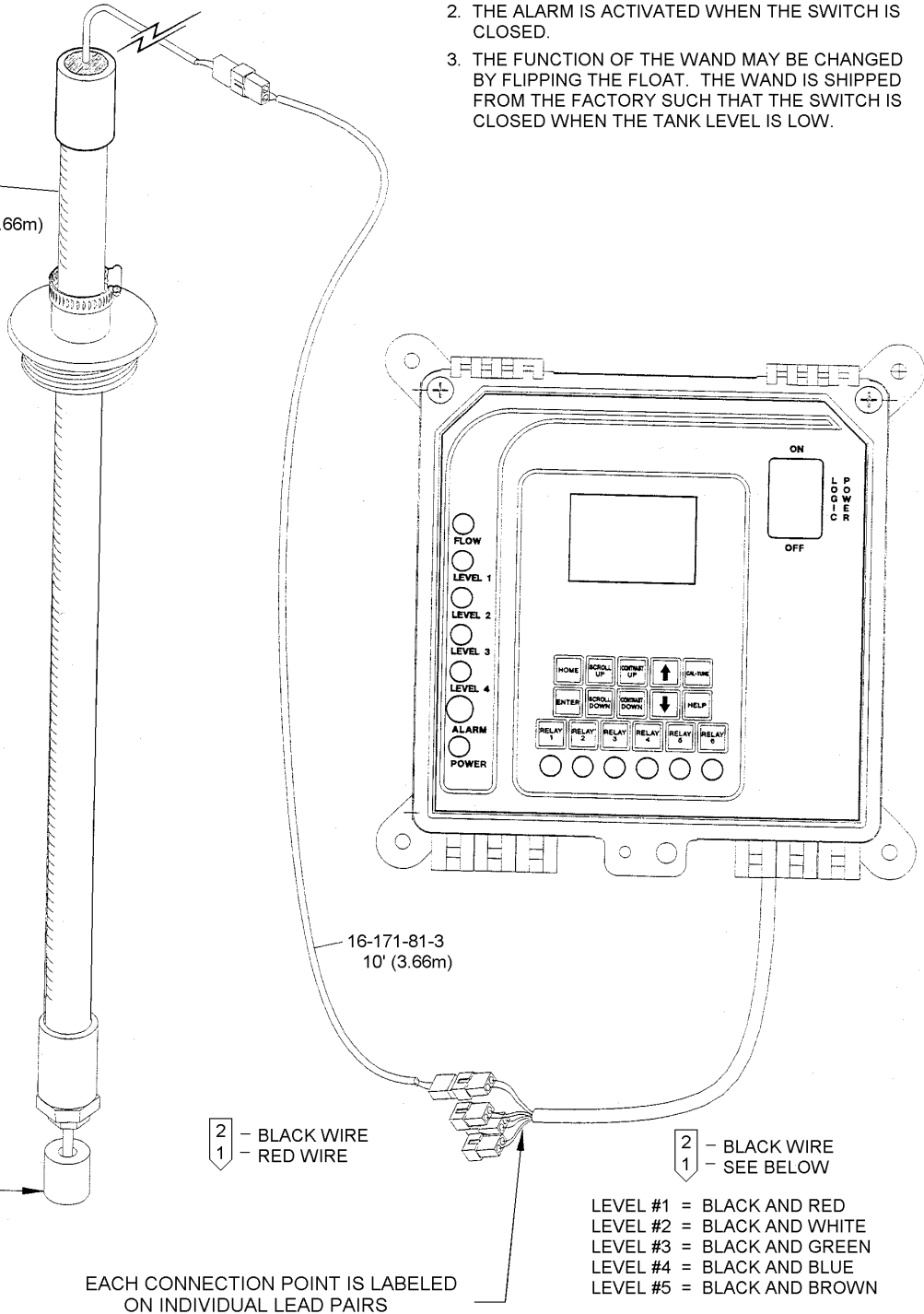

2 - BLACK WIRE
 1 - RED WIRE

2 - BLACK WIRE
 1 - SEE BELOW

LEVEL #1 = BLACK AND RED
 LEVEL #2 = BLACK AND WHITE
 LEVEL #3 = BLACK AND GREEN
 LEVEL #4 = BLACK AND BLUE
 LEVEL #5 = BLACK AND BROWN

EACH CONNECTION POINT IS LABELED
 ON INDIVIDUAL LEAD PAIRS

DIAGRAM 8 – SINGLE POINT DRUM LEVEL WAND

6. Specifications

(Factory settings are default values)

General

Power Input.....	90-250 VAC @ 50/60 Hz 100 VA.
Control Output.....	Line voltage @ 600 VA (5 amps @ 120 VAC) per relay.
Enclosure Pre-wired	High impact resistant Polystyrene™ designed to NEMA 4X (IP65), with convenient molded receptacle cords and power cord with molded plug for electrical connections.
Enclosure Conduit	High impact resistant Polystyrene designed to NEMA 4X (IP65), factory predrilled with easily accessible terminals for hard wiring.
Display.....	64 X 128 pixel dot matrix backlit display (8 line by 20 characters).
Logic Power Switch.....	Recessed front panel.
H/O/A Switches.....	Front panel keypad.
Contrast Adjustment.....	Front panel keypad.
Lockable Viewing Window.....	Standard
Security Code	Multiple standard.
Environment.....	Ambient temp. 0°F (-17.8°C) to 122°F (50°C); relative humidity 0 to 100%.
Dimensions.....	Width 10" (25.40 cm) X height 10" (25.40 cm) X depth 7.08" (17.98)
Controller Weight.....	18 lbs. (8.16 kg)
Shipping Weight.....	22 lbs. (9.98 kg)
Flow Switch or Interlock	Connection provided. Function activated by dip switch if mounted flow switch or remote flow switch not ordered with controller.
Inputs	8 analog and 8 digital (max - depends on model).
Outputs.....	4 analog and 7 relays (max - depends on model).

Summary Of Keypad

Home	When pushed, returns displayed menu back one level in menu structure.
Enter	When pushed, enters displayed variable or value.
Scroll Up.....	Used to move prompt to line above current line.
Scroll Down	Used to move prompt to line below current line.
Contrast Keys	Used to control contrast of viewing screen.
Arrow Keys	Used to increase/decrease numerical settings, select between list items.
Cal-Tune	Used to access Calibration-Tune menu directly.
Help	Used to display information about present displayed menu level.
Relay Keys	Hand/Off/Auto (HOA) switches, depressing key: ONCE - Forces corresponding output relay on for five minutes; LED color amber. TWICE - Forces corresponding output relay off until power is cycled or key pressed; LED color red. THREE times - Returns control to automatic; LED off if within set point, green if out of set point.

Summary Of LED Indicator Lights

Power Indicator	illuminates green when power is supplied to unit.
Flow Indicator	illuminates when flow is present through flow switch.
..... GREEN -	Indicates flow
..... RED -	Indicates no flow
..... OFF -	Indicates disabled
Level Indicator	GREEN if level OK (switch open).
.....	RED if level low (switch closed).
Alarm Indicator	Flashes red when an alarm condition is present.
Relay Indicators.....	AMBER if forced on.
..... RED -	If forced off.
..... OFF -	If in auto mode and control function is not automatically activated.
..... GREEN -	If activated automatically.

7. Factory Default Values



Your controller may not include all of these features

NOTE

DRUM LEVEL INPUT

Alarm LED/RELAY/CALLBACK YES / YES / YES

TIMER

Type DISABLED

TIMER: 28-DAY

Run Time 01:30 HH:MM
Program: Start Time 00:00 HH:MM
Program: Month EVERY MONTH
Program: Week EVERY WEEK
Program: Day NO DAY

TIMER: PERCENT

Percent 0%
Percent Minutes 10

TIMER: CYCLE

OFF TIME 01:30 HH:MM
ON TIME 00:30 HH:MM
CYCLES/DAY 12
Program: Start Time 00:00 HH:MM
Program: Month EVERY MONTH
Program: Week EVERY WEEK
Program: Day NO DAY

TIMER: PULSE

Run Time 00:30 MM:SS
Pulse Set 10
Water Meter One

WATER METER

Multiplier 100
Type Meter
Active Closed
Time .80 Seconds
Relay Links NO/NO/NO/NO/NO/NO

SECURITY

Master Password (NONE)
User Password (NONE)
Set points NO
Timers NO

COMMUNICATIONS

Baud Rate	19200
Interval	1 minute
Event Driven	Off
Modem Setup String	&FE0V0X4S0=1&D0
Alarm LED/RELAY/CALLBACK	NO / NO / YES
Callback: Active	OFF
Callback: Device ID	DEVICE-0
Callback: Remote Number	(NONE)
Callback: Pager Number	(NONE)
Callback: Pager ID	,1,2,3,4,*001*?*#

LEVEL INPUT

Type	Level
Active	Closed
Time	5 Seconds
Relay Links	NO / NO / NO / NO / NO / NO
Alarm LED/RELAY/CALLBACK	YES / YES / YES

FLOW INPUT

Type	Flow
Active	Closed
Time	1.5 Seconds
Relay Links	YES / YES / YES / YES / YES / YES
Alarm LED/RELAY/CALLBACK	YES / YES / YES

FACTORY INITIALIZE

Alarm LED/RELAY/CALLBACK	YES / YES / NO
--------------------------	----------------

8. Trouble Shooting Guide

If your controller is not operating properly, proceed through the troubleshooting instructions below.

Mother Board

Symptom	Probable Cause	Possible Solution
Keypad Sluggish / Locked Up.	Serial communications in progress.	<ul style="list-style-type: none"> • Wait for response. • Discontinue serial communications/disable alarm callback. • Cycle power.
No Display (See Power Supply first).	Improper contrast	Adjust using [CONTRAST UP] / [CONTRAST DOWN] keys.
	Environment exceeds 122°F (50°C)	Relocate controller.
	Connection loose or not made from mother board to display.	Press on front panel around display. Remove mother board and re-connect display.
	No power to mother board.	Check cable from power supply. Check power supply.
	Failed display.	Replace display.
Display Garbled.	Loose connections.	Press front panel around display, or remove mother board and re-connect.
	Power supply voltage out of specification.	Replace.
	Power applied to digital input.	Disconnect ribbon cable from relay board to mother board – check digital inputs with volt meter.
	Mother board failure.	Run diagnostics. Turn mother board S1 - 7 & 8 'ON' (see <i>Section 5 – Diagram 3</i>) then cycle power. Replace mother board and software.
	Bad EPROM.	Replace EPROM.
	Power surge.	Factory re-initialize. Turn mother board S1 - 8 'ON' (see <i>Section 5 – Diagram 3</i>) and cycle power.
	Loop powered outputs from 4-20mA card	Remove input.
Display too dark or light.	Contrast off due to temperature fluctuation.	Adjust contrast. Control ambient temperature.
Display backlit, but not working.	Mother board/EPROM failure.	Re-initialize. Replace mother board.
	Power supply voltage out of specification	Replace.
Erratic Readings.	Improperly grounded power	Assure power and ground integrity. Shields of all sensors should be connected at controller end only.
Flow Light Never Activates (Green indicates ON, Red indicates OFF).	Function not activated	TURN POWER OFF! Turn switch S1-'2" on mother board ON. See <i>Section 5 – Diagram 3</i> . TURN POWER ON.
Flow Light Stays On (Green) in No Flow	Flow switch stuck up.	Clean flow sensor (see <i>Section 9 – Maintenance</i>).
	Flow switch cap bad.	Check for wire integrity or replace flow cap.

Condition.		Check relay board positions 11 and 12 on J11 for installed jumper. Refer to <i>Section 5 – Diagram 2.</i>
Flow Light does not come On (Green) in Flow Condition.	Flow switch dirty or stuck down.	Clean flow switch assembly.
	Inadequate flow.	Increase flow. One GPM (3.8 l/m) minimum.
	Bad shuttle.	Replace shuttle. Refer to <i>Section 9 – Maintenance.</i>
	Bad flow cap.	Replace cap.
	Wiring loose or incorrect.	Check flow switch wiring connections on relay board. Refer to <i>Section 5 – Diagram 2.</i>
Level Lights remain Green with Low/No Level Input.	Level switch dirty or stuck	Clean level.
	Level magnet in wrong orientation.	Reverse magnet orientation.
	Bad/wrong switch type.	Assure dry contact (reed switch) type.
	Wiring loose or incorrect.	Check level wiring to quick connect. Refer to <i>Section 5 – Diagram 8,</i> then to <i>Section 5 – Diagram 2.</i>
	Float bouncing.	Contact must continuously be closed for 15 seconds for the controller to recognize.

Power Supply Board

Symptom	Probable Cause	Possible Solution
No POWER LIGHT.	Power switch off.	Turn power switch ON.
	Blown fuse.	Replace fuse on Power Supply board. See <i>Section 5 – Diagram 7,</i> for replacement information.
	No power supplied.	Check power source.
	Interconnecting cables loose.	Check connections.
Use the Following Procedure to Diagnose Power Related Problems: CAUTION – MAIN VOLTAGE WILL EXIST AT THE CONNECTIONS YOU TEST!	1. Check power at source (into relay board at J12 Phoenix connector). If power is there, proceed, if not, check supply power.	
	2. Check for power to the power supply at J13 on relay board. If power is there proceed, if not, replace relay board.	
	3. Check power after the wire cable from J13 to the power supply J1 (see <i>Section 5 – Diagram 7</i>). If power is there, proceed, if not, replace cable.	
	4. Check fuse on power supply. If okay, proceed, if not, replace fuse or power supply. See <i>Section 5 – Diagram 7,</i> for replacement information.	
	5. Check voltages at output of power supply J2 (see <i>Section 5 – Diagram 7</i>). If okay, proceed, if not, check power switch is turned on. If still no voltage, replace power supply.	
	6. Check voltages at mother board J12 (see <i>Section 5 – Diagram 3</i>). If okay proceed, if not, check and/or replace power supply to mother board cable.	
	7. If voltage exists at mother board, but you have no display or lights on the front panel, refer to <i>Motherboard</i> section of trouble shooting guide.	

Relay Board

Symptom	Probable Cause	Possible Solution
No Outputs. Note: Each relay, on the Relay Board, has a fuse and a red LED.	If the Output front panel LED is lit and the Relay board LED is not lit: <ul style="list-style-type: none"> • ribbon cable. 	Check ribbon cable between mother board and relay for good connection. Runs between J10 on relay board and J3 on mother board (see <i>Section 5 – Diagram 2 and Diagram 3</i>). Replace if necessary.
	If the Output front panel LED is lit and the Relay board LED is also lit: <ul style="list-style-type: none"> • blown fuse • bad relay 	Replace fuse, if necessary, or replace relay. See <i>Section 5 – Diagram 2</i> , for replacement information.
	If the Output front panel (relay) LED is not lit and the Flow LED is red.	Check for flow and flow switch.
	No Flow	Relays are forced off with loss of flow (configuration dependent).
	Limit timers exceeded.	Interrupt flow, satisfy condition or cycle power.

TIMER

Symptom	Probable Cause	Possible Solution
Timer Does Not Activate.	No flow.	Restore flow.
	Improper settings.	Check type selection.
	No water meter input	Check meter and wiring.
	Timer locked out during biocide feed.	Wait for biocide to finish.
	Timer exceeded	Reset by interrupting flow, satisfying the condition, cycling power, or changing setting.
	Improper settings.	Check type selection settings.
No Output for a Particular Function.	Timer exceeded.	Interrupt flow if flow switch included. Cycle power or satisfy control parameters.

TIME, SETTINGS, HISTORY

Symptom	Probable Cause	Possible Solution
Inability to keep Time/Date/Settings/History.	Line power spikes	Provide spike protector and uninterrupted power supply.
	Software failure	Replace EPROM.
	Hardware failure	Replace mother board.
	Improper wiring creating ground loop interference	Check all power wiring including relays and digital inputs. Refer to power supply troubleshooting section and <i>Section 5 – Diagram 2</i> .
	Experiencing data changes with brownouts when it falls below 90V	Perform factory Re-Init located in Configure menu. Install surge suppressor. Refer to <i>Factory Re-Installation</i> section.

Serial/Modem Communications: Modem will not answer a phone call.

Symptom	Probable Cause	Possible Solution
<p>You have purchased the Serial Communications Option and attached the controller to the phone line with the cables provided. You dial the controller's telephone number with a voice phone (i.e., the type of phone that you would use to call your mother) and the extension rings but the controller's modem does not answer (i.e., the line continues to ring).</p>	Modem option not installed.	Open controller and verify installation of Modem Module. See <i>Section 5 – Diagram 5</i> . If necessary, purchase upgrade.
	Digital Phone System.	The phone line your controller is attached to must be analog. Contact your telephone service provider to determine if the line is digital. Digital phone lines are common in newer PBX systems. Digital phone systems tend to have special phones that all look similar. Analog service is installed in most residential locations. Digital phone lines can damage the modem module and void your warranty.
	Phone line adapter not used.	The cord that exits the controller with the RJ-45 connector is NOT wired in accordance with standard telephone wiring conventions. If you are installing the controller without the telephone line adapter, the RJ-45 outlet box must be wired in accordance with the Telephone line adapter. See <i>Section 5 – Diagram 6</i> .
	Modem setup string problem	The modem setup string must contain the command S0=1 to tell the modem to pick up the line. If this command is missing the modem will not pick up the line. If you are attempting to use an external modem with the controller, it is possible that the modem is rejecting the setup string and disregarding the S0=1 command. Use the QUICK TESTS, Initialize MODEM selection to verify setup string acceptance.
	Incorrect BAUD rate setting	If you are attempting to use an external modem with the controller, it is possible that the modem is rejecting the setup string due to the selection of an unsupported BAUD rate. Consult your modem documentation to determine the supported baud rate. The standard 14.4K BAUD internal modem will support all BAUD rate options. The non-standard 2400 BAUD internal modem will only support baud rates of 2400 and below.
	Cable/Connection problem	If one of the cables or connections is faulty, the modem may fail to pick-up the phone line. To verify the connections, open the controller and observe the Red and Green LED's near the ejector latch on the Serial Communications Daughter Card. Use a voice phone to dial the controller's phone number. Observe the Green LED. It should flash briefly every time the phone rings. If it does not, check the cable connections. Use <i>Section 5 – Diagram 6</i> to verify conductivity between the TIP and Ring lines for the telephone line to the controller

Serial/Modem Communications: Modem answers and synchronizes, but will not communicate.

Symptom	Probable Cause	Possible Solution
You have purchased the Serial Communications Option and attached the controller to the phone line with the cables provided. You dial the controller's telephone number with your communications package. At your PC, you hear the line ring, the controller answer and the remote modem's carrier (a sound similar to the squealing of truck brakes). The carrier tone stops, but your communications package reports a communications error.	Modem setup string problem.	Use the QUICK TESTS, Initialize MODEM selection to verify setup string acceptance. Follow the Quick Tests trouble shooting item in the Trouble Shooting Guide section of this addendum. If you are attempting to use an external modem with the controller (a non-standard configuration), it is possible that you are not using the correct setup string. Some modems will communicate across the phone line at one baud rate (modem-to-modem), then communicate to the attached equipment at another (modem-to-controller). The standard internal modem works in this fashion. Other modems will carry the baud rate through the entire connection (modem-to-modem and modem-to-controller). These modems need to be told to use the modem-to-controller baud rate through the entire connection (modem-to-modem and modem-to-controller). To do this, try adding the &B1 command to the end of the setup string as follows: "&FE0V0X4S0=1&D0&B1" . Then set the controller's BAUD rate to a known good BAUD rate for the modem (9600 or 19200 BAUD tend to be widely supported). Consult your modem documentation for further setup-string information.
	Incorrect BAUD rate setting at controller.	In the COMM SETTINGS menu, select the baud rate at which you plan to communicate. For example, if you have a 2400 baud modem on your PC, set the BAUD rate to 2400. Typically, you can improve performance by selecting a BAUD rate that is higher than the communications rate (that is why the default for the internal modem is 19.2K even though the modem is only capable of 14.4K). Once you get your connection working you can try higher BAUD rates to determine if you can increase performance. The standard 14.4K BAUD internal modem will support all BAUD rate options. The non-standard 2400 BAUD internal modem will only support baud rates of 2400 and below. Follow the solutions for the 'Modem Setup String Problem' Probable cause in this section.
	Incorrect BAUD rate setting at the PC.	While many modems claim to be Hayes compatible, it only means that they conform to the Hayes command set. It does not mean that the modem defaults conform to the Hayes standard. Therefore, it is possible that a given modem will not work with your communications setting. Begin by setting your PC communications package modem connection to the same rate set in the COMM SETTINGS menu and one that is within the capacity of your modem (at or below the publicized baud rate of the modem - if you are using a 14.4KBAUD modem try 9600). Try updating your serial communications package. Due to this problem, newer communications software will automatically adjust its baud rate to conform to the modems baud rate.
	Serial Communications daughter card not installed properly.	Assure that the serial communications daughter card is firmly seated in the connector and that all pins mate properly. Note that the connector has a double row of pins. Assure that the pins are not offset from the connector by one row.

Quick Tests: Initialize Modem / Quick CALLOUT / Quick PAGE Time Out Error.

Symptom	Probable Cause	Possible Solution
<p>When performing a Quick Test (Init MODEM, Quick CALLOUT or QUICK PAGE) the following message sequence displays: 'Initializing...' followed by 'Time Out ERROR !!!'. This typically means that the controller was not able to communicate with your modem.</p>	Internal/External modem cannot communicate at the selected baud rate.	In the COMM SETTINGS menu, change the BAUD rate to one that works with your modem. Refer to <i>Section 4 – Communications</i> , for further information.
	Internal/External Modem is busy. (e.g.: it has the phone line off the hook and is ignoring commands).	Wait 60 seconds and try the test again.
	Internal Modem not installed / damaged.	Disconnect power. Open controller and examine installation of modem module. Assure module is firmly seated and all pins meet with socket (2 pins are missing from this device - this in normal). Refer to <i>Section 5 – Diagram 5</i> .
	External Modem cable not configured properly.	If you are using an External modem, it is possible that the cable has a bad connection. Refer to <i>Section 5 – Diagram 6</i> for cable pinouts.
	Dial-up also not functioning.	Refer to the <i>Section 8 – Trouble Shooting, Serial/Modem Communications</i> : Modem will not answer a phone call for further diagnostic steps.
<p>When performing a Quick CALLOUT, or Quick PAGE the following message sequence displays: 'Initializing...' 'OK' 'Dialing XXXXXXX' then possibly 'CONNECT' and finally 'Time Out ERROR !!!' or 'No Dial Tone'. This typically means that the controller was able to communicate with your modem, but could not communicate with the remote device.</p>	The phone line is not correctly attached to the Communications Daughter Card	Verify correct wiring. Make sure all connections are tight and protected from water. Refer to <i>Section 5 – Diagram 6</i> for further wiring information.
	The phone number is not configured properly.	Check the CALLOUT and PAGE phone numbers in the ALARM CALLBACK setup menu. If you are dialing out through a PBX system, do not forget the outside line access code (e.g., you must dial 90 to gain access to an outside line). Note: If you are calling a local number, do not enter an area code in the dialing prefix.
	The remote computer is not turned on and running your communications package.	Check the number. Using a voice phone near the controller's location, dial the number of the remote computer or pager service. You should hear either the modem carrier or pager prompt when the remote system picks up the line.
	Local phone line extension is digital.	The internal modem will not operate on a digital phone line. Check with your phone service provider to determine if the line is analog (OK) or digital (BAD). If necessary, upgrade the service.

Quick Tests: Message Definitions

Symptom	Probable Cause	Possible Solution
Initializing	The controller is attempting to talk to the modem.	None. Good response.
Dialing XXXXXXXX	The controller is dialing the phone number	None. Good response. Do not be alarmed if the end of the dial string is cut off. The length is limited by the display. The controller will still issue the entire dial string to the modem.
Operation complete!	Test has completed successfully	None. Normal response.
No number available.	You are attempting to perform a dial test (i.e., CALLBACK or PAGE), but do not have a phone number configured.	Go to the CALLBACK setup menu and enter the required phone number.
Time Out ERROR!!!	The controller timed out while waiting for a response from an attached piece of equipment.	Refer to QUICK TESTS trouble shooting section.
OK	The modem accepted the string that was sent to it.	None. Normal response.
CONNECT	The modem connected to another modem.	None. Normal response.
RING	The phone line is ringing.	None. Normal response
NO CARRIER	The modem dialed the number, the remote system answered, but it did not issue a carrier used to synchronize baud rates.	Check the modem on the remote system. Check the cabling. Normal response at the end of the Quick CALLOUT test.
NO DIALTONE	The modem attempted to dial the phone number but could not detect a dial tone first.	Check the telephone jack cabling. Refer to <i>Section 5 – Figure 6</i> .
BUSY	The modem dialed the designated number and received a busy signal.	Repeat the test later. Check the number with a voice phone (the phone number could be incorrect).
NO ANSWER	The modem dialed the designated number. The line was not answered after the limit number of rings (typically 10).	Check the status of the remote system. Confirm that the phone number is entered correctly.

REINITIALIZATION

If the above troubleshooting steps fail to explain or solve condition, perform a factory re-initialization (see *Factory Initialize section*). If condition still exists, contact factory for customer service assistance. A Return Authorization (RA) number is required for any return.

9. Maintenance

The only maintenance required on your controller is periodic cleaning of the sensors. It is recommended that you establish a regular maintenance schedule designed to meet the needs of your particular application. All other service should be performed by factory authorized personnel only. Modifications to or tampering with the circuit level components makes all warranties, written or implied, and/or the manufacturer's responsibility for this controller null and void.

9.1 Flow Sensor

The **Flow Sensor** uses differential pressure to cause a shuttle to rise and magnetically activate a reed switch. Occasionally this assembly may become fouled, preventing the shuttle from rising and/or falling.

To clean the assembly:

1. Close isolation valves and relieve system pressure from the flow assembly.
2. Loosen the flow cap retaining nut.
3. Remove flow cap from flow body by pulling straight out.
4. Remove red shuttle by pulling straight out. Note post shuttle rides on.
5. Clean all internal surfaces of flow body with soft bristle bottle brush. Be careful of the post that the shuttle rides on, its surfaces must be clean, but do not break it while cleaning.
6. Clean shuttle exterior surfaces and shuttle bore with a soft brush. You may use a mild dish soap if desired. Flush well before re-installing.
7. Re-install shuttle and attach flow cap. Open isolation valves. Check for leaks.

10. Internal Modem FCC Compliance Information

The following is provided to comply with the FCC Part 68 Rules that apply to the internal modem. This device is optional and as such, may not have been ordered with your controller.

Type of Service: The Internal Modem (08-600-45/49) is designed to be used on standard device telephone lines. It connects to the telephone line by means of a standard jack called the USOC RJ-11C (or USOC FJ45S). Connection to telephone company provided coin service (central office implemented systems) is prohibited. Connection to party lines service is subject to state tariffs.

Telephone Company Procedures: The goal of the telephone company is to provide you with the best service it can. In order to do this, it may occasionally be necessary for them to make changes in their equipment, operations or procedures. If these changes might affect your service or the operation of your equipment, the telephone company will give you notice, in writing, to allow you to make any changes necessary to maintain un-interrupted service.

In certain circumstances, it may be necessary for the telephone company to request information from you concerning the equipment which you have connected to your telephone line. Upon request of the telephone company, provide the FCC registration number and the ringer equivalence number (REN); both of these items are listed on the equipment label. The sum of all of the REN's on your telephone lines should be less than five in order to assure proper service from the telephone company. In some cases, a sum of five may not be usable on a given line.

If Problems Arise: If any of your telephone equipment is not operating properly, you should immediately remove it from your telephone line, as it may cause harm to the telephone network. If the telephone company notes a problem, they may temporarily discontinue service. When practical, they will notify you in advance of this disconnection. If advance notice is not feasible, you will be notified as soon as possible. When you are notified, you will be given the opportunity to correct the problem and informed of your right to file a complaint with the FCC. Contact your telephone company if you have any questions about your phone line.

11. Glossary

Alarm Relay – an electric circuit when triggered by a predetermined signal will activate an externally connected alarm

Analog – a continuous signal that can be used to represent a physical variable, e.g., conductivity, pH, or ORP

Analog Recorder – a device such as a plotter that physically stores or presents quantities of data in a physical manner

Auto Scroll – a function of the Controller which allows unit to automatically display system status, active alarms, time, date, etc.

Biocide – an agent used to control the growth of algae and other organic substances

Bleed – 1) to release water from the system, used to control conductivity
2) The amount of time the Blowdown valve will be held open after a hold period.

Blowdown – see Bleed

Blowdown Valve – the valve that opens or closes to release water from the system activated by a signal from the Controller

Buffer Solution – a solution with a specific pH value used as a control in calibrating sensors.

Calibration – a procedure to match values “read” by sensors to actual real world values

CalKit – a kit available from the manufacturer with a specific cavity volume used to calibrate conductivity sensor

Cal-Tune – button that activates the calibration-tune menu

Caustic – burning corrosive, a characteristic of some chemicals especially strong alkalis

Chattering – a situation that occurs when relay controlled device repeatedly turns off and on

Chemical Feed Pump – a relay or proportionally controlled pump that disperses chemical into the system (i.e., PULSAtron)

Chemical Metering Pump – see Chemical Feed Pump

Conductivity – the ability of a substance to conduct electrical current, concentrations of dissolved and suspended solids in water directly determine the conductivity of the water

Conduit – tubing through which wire is run

Configure – procedure to set up basic functions of the controller, i.e. date, time, set point control, etc.

Contacting head water meter – a water meter that outputs a dry contact signal every time it pulses

Contrast – difference in brightness between adjacent objects, i.e., darkness of text in screen display versus lightness of the screen background

Cooling Tower – a structure of various sizes that allows heat to radiate away from the system water

Cursor – See prompt

Cycle Timer – a timing device that can be preset to turn off and on at specific intervals

Daughter Board – an auxiliary circuit board within the controller dedicated to a specific function(s) of the controller

Differential – also referred to as dead band or hysteresis, this is a range or offset applied to a set point value (see chattering)

Dip Switch – very small switches located on a circuit board usually used in combination to configure the circuit

Double Junction – type of construction on a pH sensor where a permeable membrane separates two buffer solutions

Dry Contact – relay contacts without power

EEPROM – Electrically Erasable Programmable Only Memory

Electrodes – or sensors, the metal protrusions that measure conductivity in the conductivity sensor assembly

Float Switch – a mechanical switch that provides an electrical contact when the water level rises to a predetermined height

Flow – refers to the movement of water through the system

Flow Assembly – an option which attaches to the controller and incorporates a flow switch, sensor/sensor ports, and sample valve

Gate Valve – a type of on/off valve for controlling the flow of liquid that consists of a screw assembly that adjusts a gate that crosses the fluid flow path

GFPPL – Glass Filled Polypropylene

Ground Loops – a condition that occurs when two pieces of equipment are electrically connected but do not share the same ground point. This can result in current flow between the equipment that can result in inaccurate readings or damage to the control.

Heat Exchanger – a mechanical device that facilitates the transfer of heat between two mediums

HCl – Hydrochloric Acid

Hi Lo Alarm – a function of the controller that signals the user when conditions exceed a predetermined high or low value

History Files – information that is stored in the controller, (history files are lost if power is disrupted for more than 14 days)

HOA – abbreviation for Hands Off Auto

HOA Switches – manual relay switches or keys (relay 1 - 6) located on the control panel of the controller

Home – this key when pressed returns user to the previous menu displayed on the viewing screen, press repeatedly to return to the main menu

Hold – the amount of time a sample is captured before reading its conductivity

Independent Set Point – this feature allows user to independently set the high and low alarm values

Inhibitor – a chemical or compound used to aid the control of corrosion or scaling in the cooling tower system

Inhibitor Feed – term referring to the disbursement of inhibitor in to the system

Inhibitor Timer – a function of the controller which regulates the amount of time inhibitor is introduced to the system

Initialization – a procedure to reset the controller to original factory conditions

Inorganic Scale Deposits – undesirable precipitate formations within the cooling tower system

Inputs – receptacles or hookups for signals delivered to the controller

Interval – the amount of time between blowdown events

Isolated Input – an input (analog or digital) that is electrically isolated from main power supply and its ground

(ISO) Isolation Valves – general term which refers to valves in the system used to isolate various components of the system from the main flow

Jumper – a wire connector (shunt) that connects two points

KCl – Potassium Chloride

LED – abbreviation for Light Emitting Diode

Limit Timer – also referred to as lockout timer or feed limit timer, it limits the amount of time output is activated

Line Voltage – voltage equivalent to outside source voltage to the controller

Lockout – intentionally preventing blowdown or other functions of the system

Menu Map – printed document supplied with controller illustrating all menu item locations

Metering Pump – see chemical feed pump

Micro Siemens – unit of measure of conductivity expressed as $\mu\text{S}/\text{CM}$

Mother Board – main circuit board located in controller behind the front panel

Motorized Ball Valve – a ball valve with a positioning device activated by an electric motor

NaOH – Sodium Hydroxide

ORP – Oxidation Reduction Potential, measured in millivolts (mV) to detect and control level of chlorine or other oxidizing agents in system water

Outputs – receptacles or hookups for signals originated at the controller

Overfeed – a condition in which the quantity of an ingredient dispersed into the system exceeds the amount desired

Percent Post Blowdown – refers to the amount of time as a percentage of blowdown time that chemical feed pumps are activated when blowdown is deactivated

Percent Timer – also referred to as a cycle timer that runs continuously that activates an output to run as a percent of total cycle time

pH – the measurement of acidity or alkalinity (acid or base) of an aqueous solution

Pre Bleed – refers to the time bleed (or blowdown) is executed before biocide feed

Pre Blowdown – see Pre Bleed

Program Parameters – the user programmed settings that determine how the controller responds to conditions of the system under control

Prompt – a triangular pointer used to indicate the active menu line

Pulse – the action of a water meter that when equipped with a contact head, can generate a dry contact closure that can be read by the controller

Pulse Timer – a feature of the controller in which a timer accepts pulses from a water meter to actuate a chemical feed pump

Relay Board – a circuit board located at the back of the controller for relay outputs, water meter hookups, flow switch, etc.

Relay Indicators – lights (LEDs) located beneath the relay keys on the face of the control panel that indicate the status of individual relays

Sample – 1) to obtain a quantity of water for test purposes
2) the amount of time the blowdown valve will be held open

Sample Cock – see Sample Valve

Sample Cooler – a small heat exchanger designed to cool a small flow of boiler water to a temperature where it can exist in its liquid state at standard atmospheric pressure (i.e., it is not boiling)

Sample Line – a line through which a portion of the system water flows, where sensors and other monitoring devices are located controlled with isolation valves

Sample Stream Flow Assembly – an option (standard on many models) which is a modular assembly that mounts to the controller with quick-release sensor(s), flow switch and sample cock (or valve)

Sample Valve – small valve on the flow assembly that provides user a means to drain small quantities of water from the system for testing

Scale/Range – the adjustable monitoring range of the controller in reference to conductivity levels in the system

Security Code – a code that can be entered by the user when configuring the system to secure access to the controller settings

Sensor – a device connected to the controller which monitors or measures a characteristic value in the water, like the conductivity

Set Point – the user determined value within a monitored range at which the controller initiates action (e.g., activates a relay)

Set Point Differential – also referred to as dead band or hysteresis; the offset applied to a set point to prevent chattering of an output relay around a set point

Solenoid – an electro-magnetically controlled switch

Storage Boot – small protective rubber boot or bottle filled with a junction wetting agent found on the tip of a new pH or ORP sensor to keep tip wet during shipment and storage

System Overfeed – usually a malfunction condition where a feed pump fails in the Run (ON) condition

System Parameters – see program parameters

System pH – level of pH in the system water

TDS – abbreviation for Total Dissolved Solids, measured in terms of electrical conductivity($\mu\text{S}/\text{CM}$)

Temperature Compensation – displays conductivity as if measured at 77°F (25°C)

Temp Sensor – used to measure temperature

Throttling – the act of adjusting a valve or other flow control device to vary flow rate

Totalizer – a re-settable function of the controller which keeps count of the number of water meter pulses

mS/CM – conductivity unit of measure. Often referred to as micro Siemens

Water Hammer – a potentially damaging situation that occurs if a valve in the system is opened too quickly, where the action results in a “hammering” effect throughout the system water lines

Y-Strainer – inline filter or screen to remove debris from system flow assembly

12. Index

(HOA), 14, 70
28 Day Timer, 46, 47, 50
Acid, 85
Alarm Dry Contact, 8
Analog, 33, 70, 77, 79, 83, 84
Analog Recorder, 83
Auto Scroll, 60, 83
Blowdown, 83
Blowdown Valve, 85
Chemical Feed Pump, 84, 85
Chemical Metering Pump, 83
Computer, 79
CONTRAST, 13, 20, 74
Control Output, 70
Cycle Timer, 53, 83, 84
Daughter Board, 83
Differential, 81
Dimensions, 70
Display, 1, 12 - 14, 16, 18 - 20, 22, 25, 27, 30, 32, 33, 35, 45, 47, 51 - 53, 59, 60, 70, 74, 75, 80, 83
EEPROM, 1, 32, 83
Electrodes, 83
Enclosure Conduit, 70
External Alarm, 5
Initialization, 12, 35, 80
Inputs, 57, 70, 84
Interval, 24, 52, 53
Isolation Valves, 81, 85
Jumper, 9, 75
LED, 10, 20, 25, 32, 33, 36, 39, 42, 44, 71 - 73, 76, 77, 84
Limit Timer, 84
Menu Map, 88
Metering Pumps, 5
micro Siemens, 85
Motherboard, 7, 74 - 76
Outputs, 70, 76, 84
Overfeed, 1
Percent Timer, 1
Power Input, 70
Power Supply Board, 75
Power Switch, 7, 20, 75
Pre-Bleed, 1
Program Parameters, 85
Pulses, 1, 32, 52, 53, 59, 83, 85
QUICK TESTS, 28, 29, 77, 78, 80
Relay Board, 5, 6, 36, 74 - 76
Relay Indicators, 71, 85
Sample Cock, 85
Sample Stream Flow Assembly, 85
Sample Valve, 85
Security, 12, 20 - 22
Security Code, 70, 85
Sensors, 2, 4, 5, 8, 74, 81, 83, 85
Serial Communications, 9, 23, 28, 77, 78
Setpoint, 71, 83, 85
Setpoint Differential, 85
Solenoid, 85
Strainer, 85
System Configure, 12, 20
System Parameters, 85
System pH, 85
TDS, 85
Temp Sensor, 85
Totalizer, 85
Water Hammer, 85

13. 28-day timer (Biocide) Programming Work Sheet

(Please make copies of this sheet for future use)

Chemical Name _____ Biocide _____

Program #1 Month _____
Week _____ Day _____
Start Time: _____:_____H:M

Program #2 Month _____
Week _____ Day _____
Start Time: _____:_____H:M

Program #3 Month _____
Week _____ Day _____
Start Time: _____:_____H:M

Program #4 Month _____
Week _____ Day _____
Start Time: _____:_____H:M

Biocide ___ Run Time _____:_____H:M

Make Copies and Repeat For Each 28-Day Timer

14. Relay Assignments

Model	Relay "C"	Relay "D"	Relay "E"	Relay "F"	Relay "G"	Relay "H"	Relay "I"
Panel >	Relay 1	Relay 2	Relay 3	Relay 4	Relay 5	Relay 6	Alarm
41X	Timer #1						Alarm
42X	Timer #1	Timer #2					Alarm
43X	Timer #1	Timer #2	Timer #3				Alarm
44X	Timer #1	Timer #2	Timer #3	Timer #4			Alarm
45X	Timer #1	Timer #2	Timer #3	Timer #4	Timer #5		Alarm
46X	Timer #1	Timer #2	Timer #3	Timer #4	Timer #5	Timer #6	Alarm

Example: A model 45X has the following relay assignments: Timer #1, Timer #2, Timer #3, Timer #4, Timer #5 and Alarm (one unused relay position).